



Introduction to Tinkercad

for Teachers

Athanasios Kakarountas

INTELLIGENT SYSTEMS LABORATORY | UNIVERSITY OF THESSALY



Co-funded by the
Erasmus+ Programme
of the European Union

This project has been funded with support from the European Commission. This publication reflects the views only of the author, and the Commission cannot be held responsible for any use which may be made of the information contained therein. Project Number: 2023-1-EL01-KA220-SCH-000155463



This Guide is published as part of the “Climate Change and Natural Disasters Awareness Raising using Virtual Worlds - VR4Clima)” Project funded by the European Union's Erasmus+ programme (2022-1-FR01-KA220-SCH-000087053). It is part of A3.1 VR Course for Primary education

Title

Introduction to Tinkercad for Teachers

Year

2025

Publisher

Athanasios Kakarountas, *University of Thessaly, Greece*

Reviewers

Jovana Jankov, *Center for Promotion of Science, Serbia*

Manolis Voutsakis, *National Technical University of Athens, Greece*

Sonal Ahuja, *VRAcademi Limited, Ireland*

Maria Zarkada, *16th Experimental Primary School of Lamia, Greece*

Natalia Budinski, *Petro Kuzmjak School, Serbia*

Design and layout

University of Thessaly, Greece

Licence

CREATIVE COMMONS BY-NC-SA 4.0 DEED

Attribution-Noncommercial-Share Alike 4.0 International

You are free to:

- **Share** - copy and redistribute the material in any medium or format.
- **Adapt** - remix, transform and build upon the material.
- The licensor cannot revoke these freedoms as long as you comply with the licence conditions.

Under the following conditions:



Climate Change and Natural Disasters Awareness Raising using Virtual Worlds

- **Attribution** - You must give appropriate credit, provide a link to the licence and indicate whether any modifications have been made. You may do this in any reasonable way, but not in a way that suggests that the licensor approves of you or your use.
- **Non-commercial** - You may not use the material for commercial purposes.
- **ShareAlike** - If you remix, transform or develop the material, you must distribute your contributions under the same licence as the original.
- **No additional restrictions** - You may not apply any legal conditions or technological measures that legally prevent others from doing anything the licence allows...

Notices:

- You are not required to comply with the licence for material in the public domain or where your use is permitted by an applicable exception or limitation.
- No warranty is given. The licence may not give you all the authorisations necessary for the use you wish to make of it. For example, other rights such as publicity, privacy or moral rights, may restrict your use of the material...

Disclaimer: This project has been funded with support from the European Commission. This publication reflects the views only of the author, and the Commission cannot be held responsible for any use which may be made of the information contained therein. Project Number: 2023-1-EL01-KA220-SCH-000155463



CONTENTS

Introduction.....	4
Creating an account in Tinkercad.....	5
Once inside Tinkercad.....	7
Editing shapes in Tinkercad.....	11
Let's create our first project!.....	12
Working with Text and custom shapes.....	18
Let's create a sign.....	20
Let's create a greenhouse!.....	25
Let's create a Windmill.....	40
Let's create a solar water heater.....	67
Create your class in Tinkercad.....	91



Introduction

This document presents the Educators' Guide for Tinkercad, which is going to be used in the Erasmus+ project 2023-1-EL01_KA220-SCH-000155463 "Climate Change and Natural Disasters Awareness Raising using Virtual Worlds" (VR4Clima). It is developed in the scope of the work package 3 (WP3: VR Course A3.1 VR Course) of the project.

This document is created by the coordinator of the project, Intelligent Systems Laboratory (ISL) of the University of Thessaly.

VR4Clima project aims to raise awareness in students about climate change and sustainable development. Students' actions and choices can mitigate the climate change from which their countries and local communities have suffered so much. During the project, a sustainable school yard design will be proposed by students. This project aims in using VR and 3d Design in education. Students will learn about serious gaming and will create 3d models themselves. Teachers will have the chance to embed 3d design and Virtual Reality in their classes.

The results of this project will be a 3d game on sustainability and climate change mitigation and school reports about students' choices. Also, 10 animation videos and a chart mapping microclimates. Two VR Courses will be delivered (for Primary and Secondary Education). There, students will design their sustainable school yard and will be able to count it's carbon footprint. Then, they will import their design in Virtual Reality and invite their peers inside their Virtual World. Online workshops for teachers will be organized, to help them embed this technology in their classes. A school contest will invite students all over Europe to submit their designs of sustainable school yards. A report on how to embed this approach in school curricula will also be done and all designs will be uploaded to a Virtual World.

The Educators' Guide for Tinkercad aims to assist educators of Primary and Secondary Education deliver a Tinkercad course in their classes and have their students design a 3d sustainable element. The students will export the design from Tinkercad and insert it in their Virtual World in CoSpaces



Creating an account in Tinkercad

Go to tinkercad.com

Click on the Sign Up button

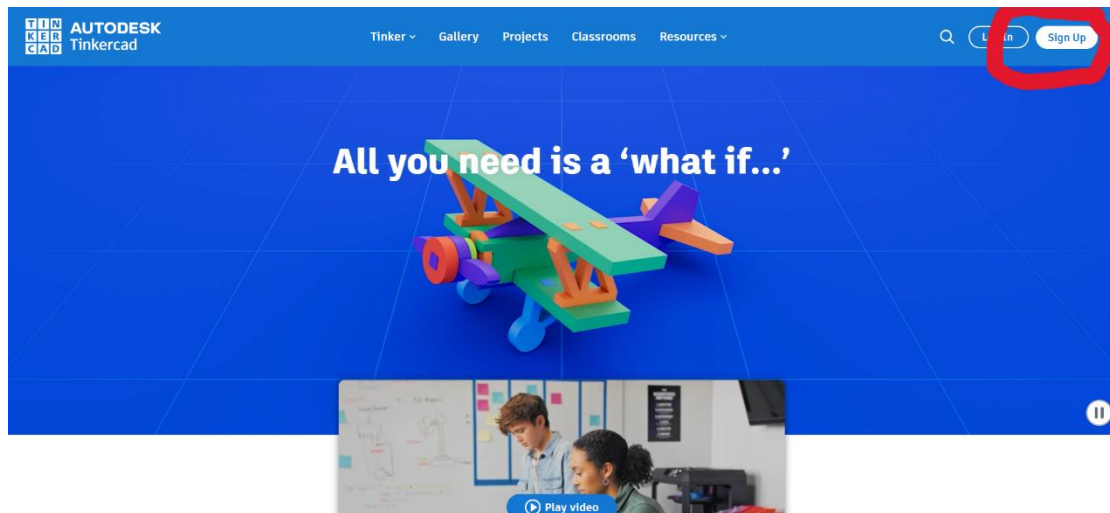

Click on "Create Personal Account"

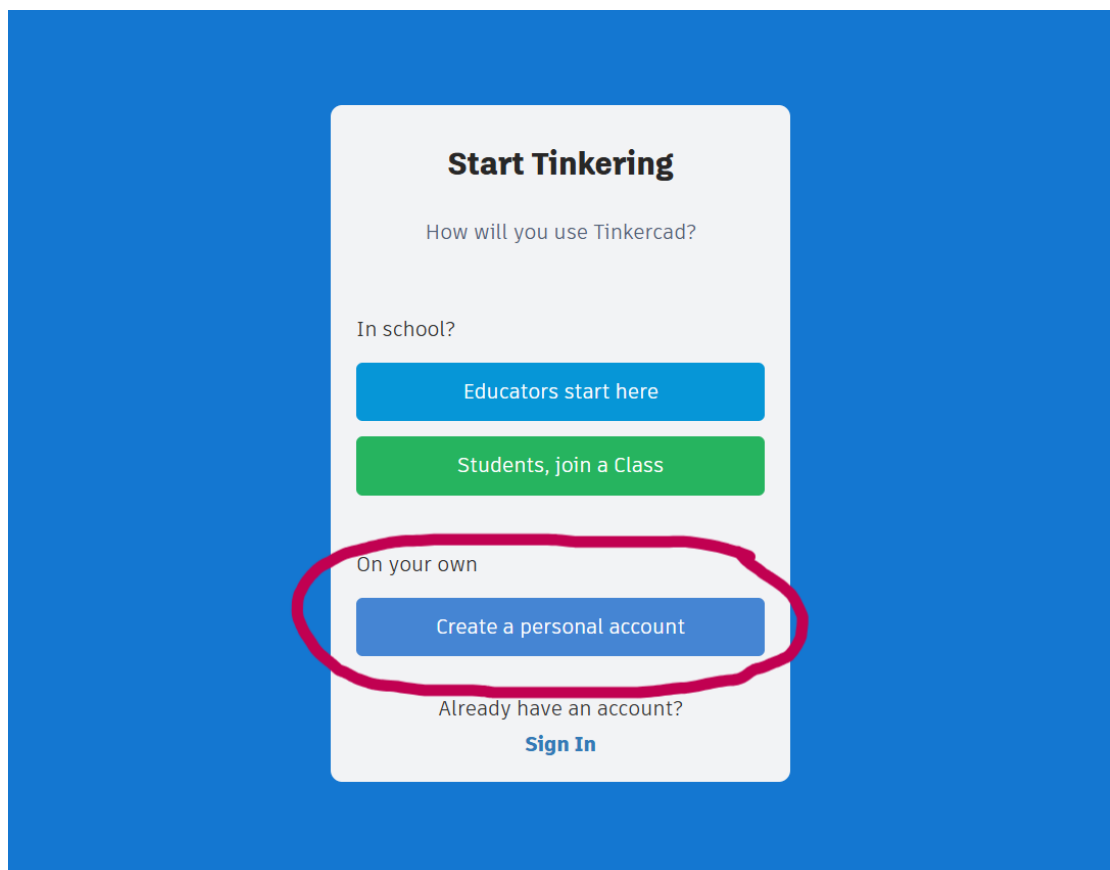



Select a way to sign Up, eg. Sign in with Google

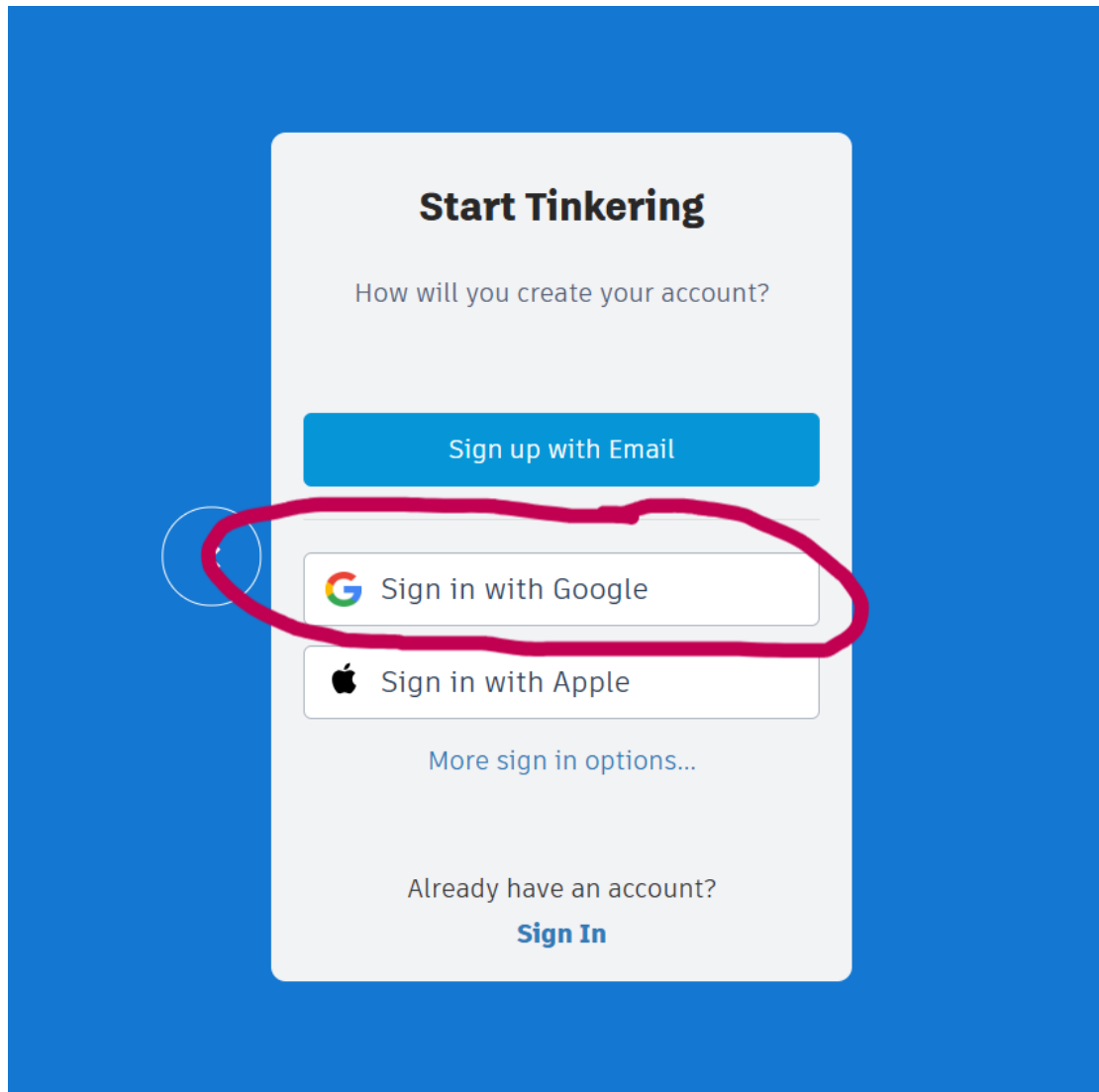





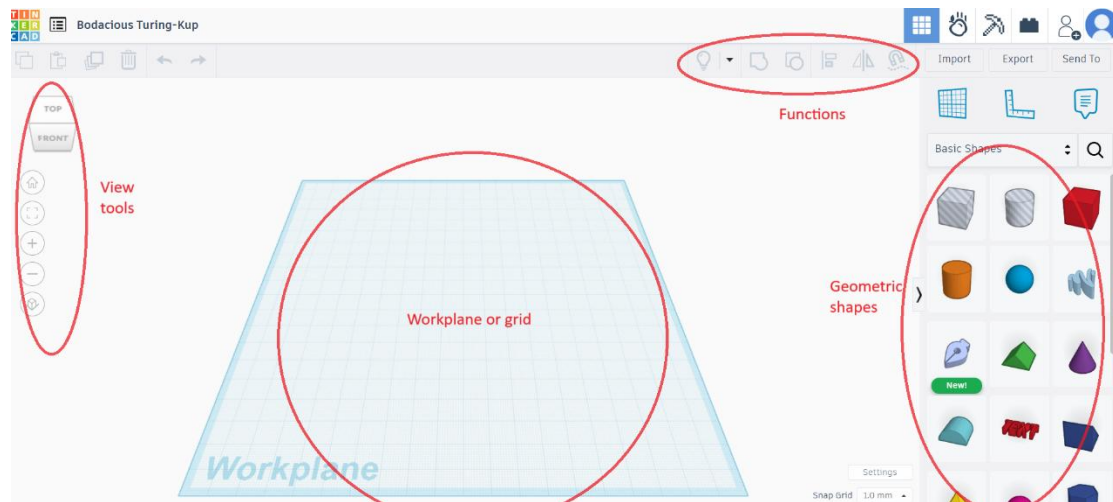



Once inside Tinkercad...



Functions

	Show all	Ctrl + Shift + H	It shows all hidden shapes
	Group	Ctrl + G	Groups 2 or more shapes together. You select the shapes clicking Ctrl + each one of them and then you click the group tool.
	Ungroup	Ctrl + Shift + G	Ungroups the shapes that have been grouped together
	Align	L	Aligns 2 or more objects in the 3 dimensions, so that each one is positioned in the center or one of its edges
	Mirror	M	Reflects an object in the x, y or z axes.
	Cruise	C	First select the shape and by clicking Cruise you can place it on top of any surface in your design.

Note: When grouping 2 or more shapes together, the shape that is created has 1 color. If the grouped shapes had different colors and you wish to keep their original color, you click on its color and instead of solid, you select Multicolor.



View tools

	View cube		Left click on it and see one object from different angles
	Home view		Brings you back to the first view when you open the project
	Fit all in view	F	Focuses on the specific object you have selected
	Zoom in	+	Zooms in (you can also use the mouse wheel)
	Zoom out	-	Zooms out (you can also use the mouse wheel)
	Orthographic view		Offers a more natural, bird's eye look at the model

Editing tools

	Copy	Ctrl + C	Copies the selected object
	Paste	Ctrl + V	Pastes the selected object
	Duplicate and repeat	Ctrl + D	It remembers your previous action. When you use it, it pastes the selected object but also performs your previous action on it.
	Delete	Delete	Deletes the selected object
	Undo	Ctrl + Z	Undos your last action
	Redo	Ctrl + Y	Redos what you undid.



Tools for shapes

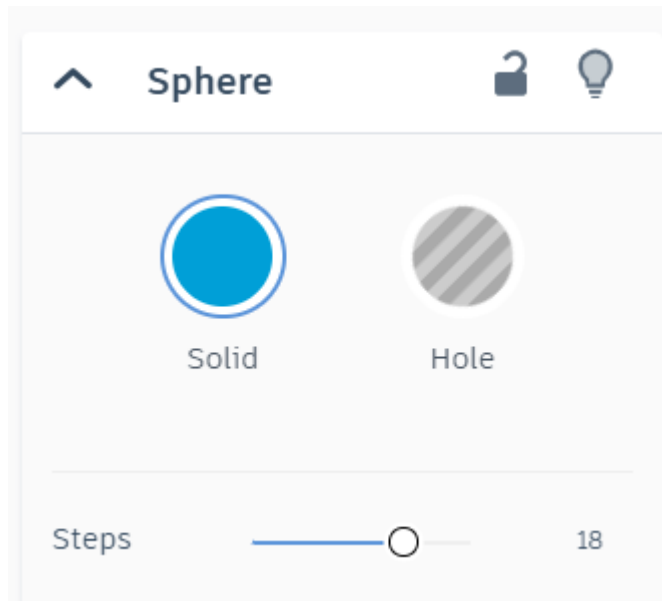

If you click on the lock button, it locks editing, so you cannot change the dimensions of the shape.

If you click on the bulb button, your shape is hidden. To make it visible again you click on the Show All button on the main menu.

If you click the Hole button your shape will become transparent. If you group it with another shape, the common space of the 2 items will disappear, leaving a hole in this place.

Steps define how smooth your object is. The more the steps, the smoother your object is but also the “heavier it gets”.



Shapes library

You can choose between several groups of shapes

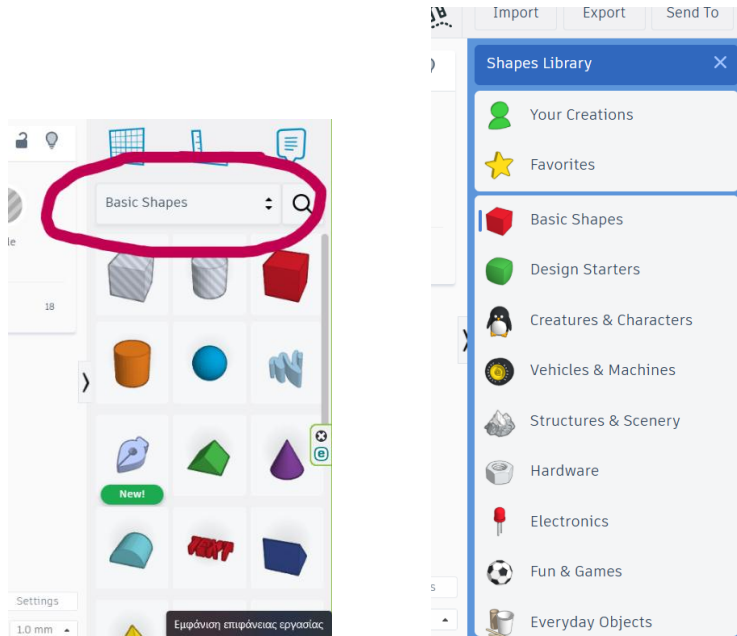



Editing shapes in Tinkercad

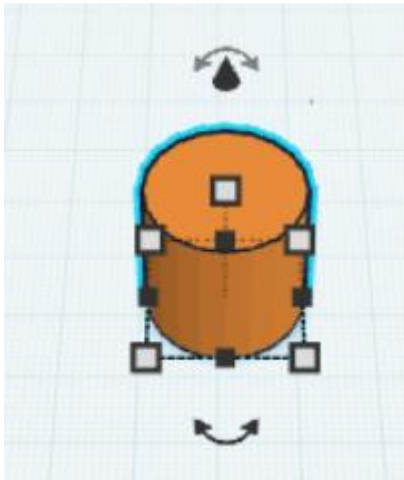

When you click on a shape, these black and white dots appear alongside it.

If you drag the white dots by clicking your left mouse button, width and length change simultaneously. NB the white dot in the middle changes only one dimension, the height of the object.

By dragging the black dots you change width or length.

If you want to lift the shape up or down you drag the black cone above the shape. To position it back on the workplane, you click D.

You can rotate the shape in 3 dimensions using the semi circles.

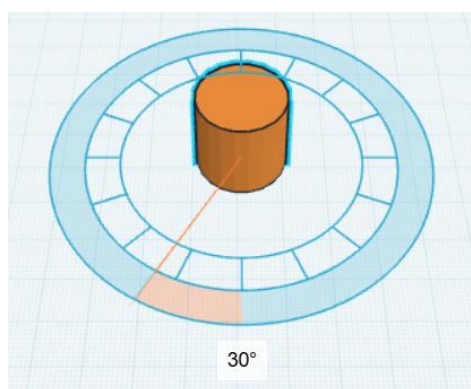
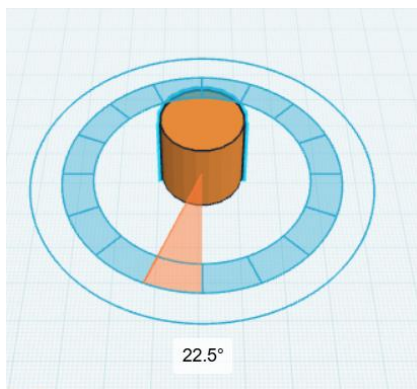
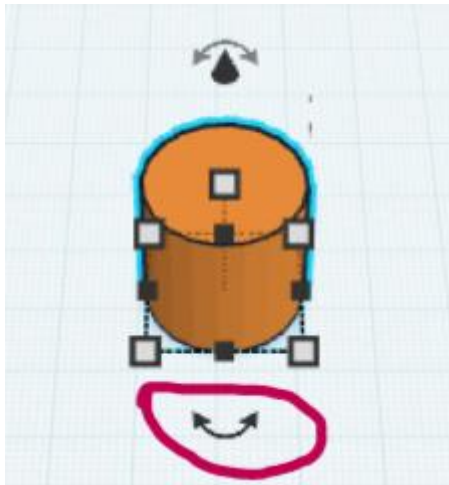

If you click on the inner cycle the rotation step is 22.5° . In the outer cycle the rotation step is 1° .



Let's create our first project!

We will create a simple house.

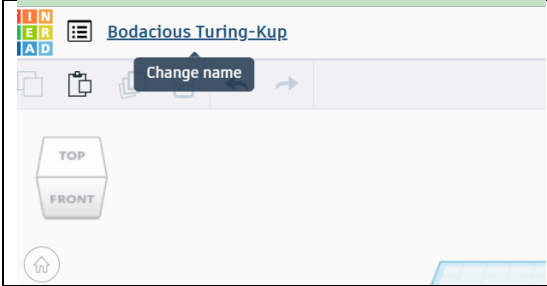
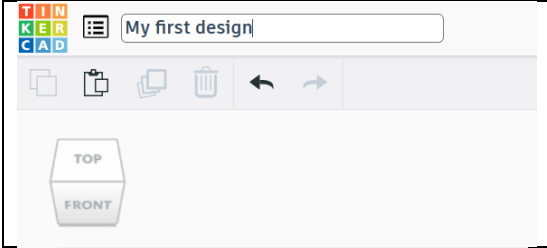
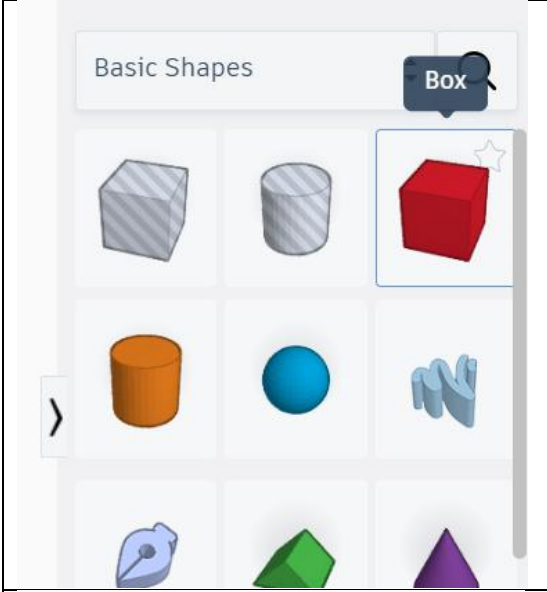
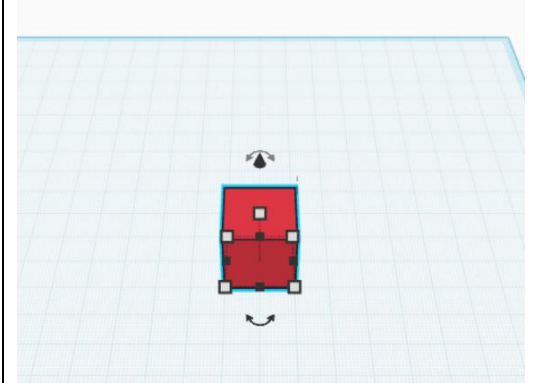
	<p>First you change the name of your project. Click on the random name given by Tinkercad</p>
	<p>Fill in the name of your project</p>
	<p>Select the Box from the library of basic Shapes on the right</p>
	<p>Drag and drop it in the workplane (using the left mouse button)</p>

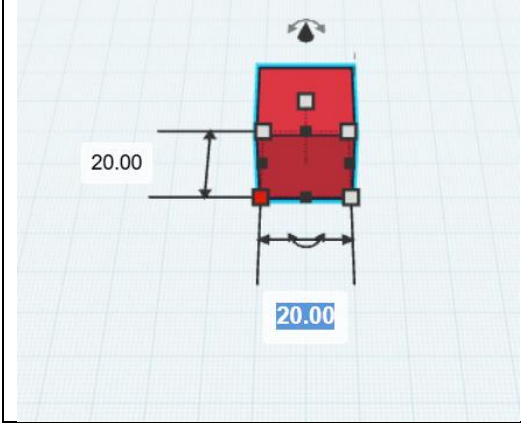
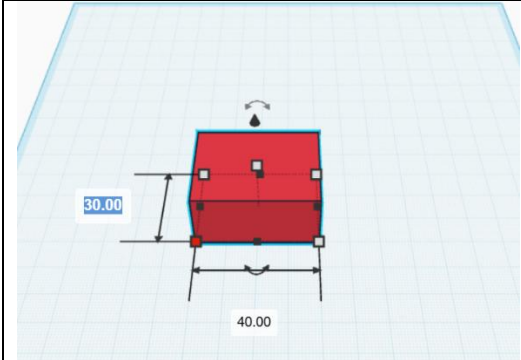
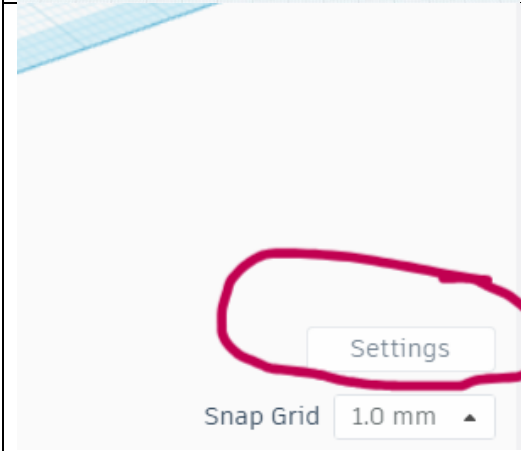
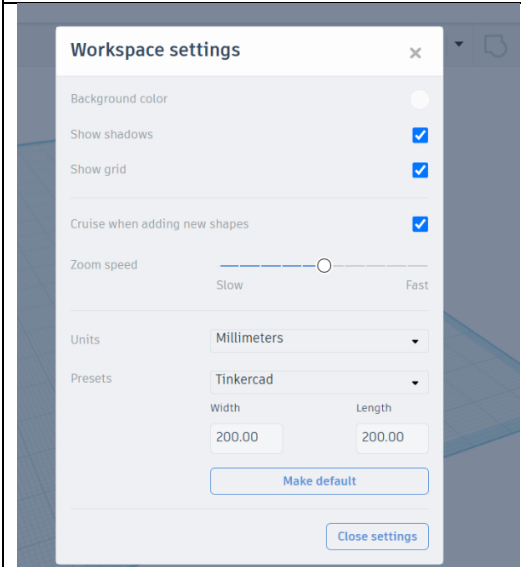

	<p>Click on the object in order to change its dimensions</p>
	<p>You can drag the white or black squares until you reach these dimensions or click on one white square and add the dimensions manually (suggested). Make width 40 mm and length 30 mm.</p>
	<p>If you wonder why it is measured in mm, go to the Settings Button on the bottom right corner of your workspace</p>
	<p>You can see that the units are mm. You can change it to inches if you wish. All your dimensions will be converted to inches</p>

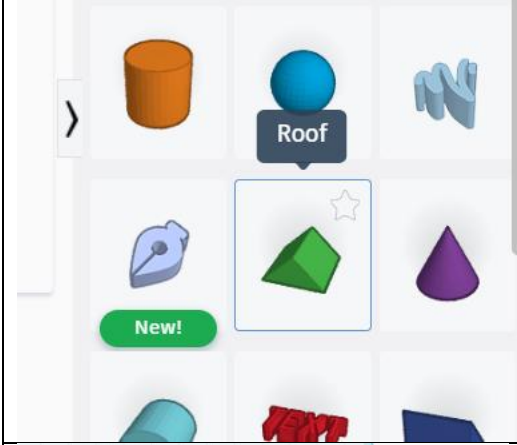
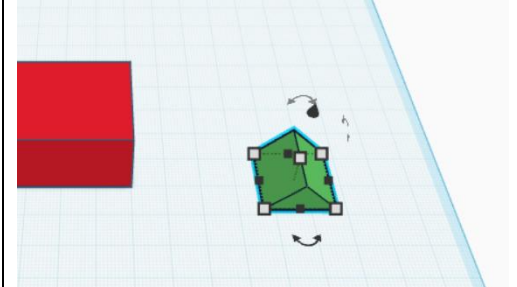
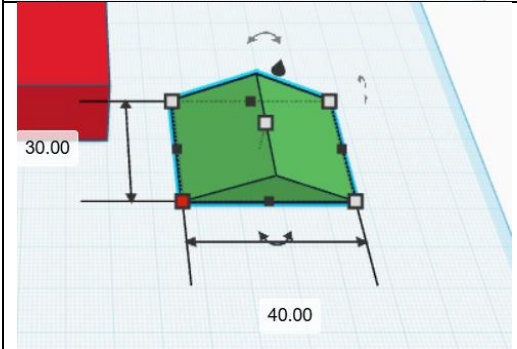
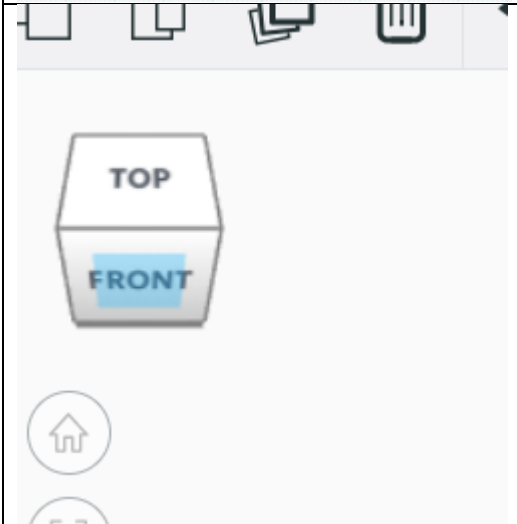

	<p>Select the Roof shape and drag and drop it to your workplane, next to the Box</p>
	<p>Click on it to change its dimensions</p>
	<p>The dimensions should be the same as the house if we want this to fit to the Box completely</p>
	<p>Click on the front side of your View cube</p>



	<p>You now see the front side of your design. You have to lift the roof at the height of the Box, which is 20 since we haven't changed it</p>
	<p>This shot shows you that you have lifted the Roof 20 mm</p>
	<p>Click on the Home view again</p>
	<p>Select the 2 shapes by placing your mouse on the top right side next to the box and drag it until the bottom right side of the Roof. Another way to select more than one objects is to select the first and then Ctrl + Click each of the rest</p>
	<p>The 2 shapes have been selected</p>



	<p>Click on the Align Tool on the top right of your screen</p>
	<p>Click on the front middle circle to select it. The items will be aligned in the middle. You can see the final result in transparency</p>
	<p>Click on the side middle circle to select it. The shapes will be aligned in the side middle</p>
	<p>Once you have aligned the 2 shapes drag a Hole Box in your workplane. You are going to shape the door of the house with it.</p>
	<p>Change the width to 5 or more, if you wish your door to be wider</p>



Climate Change and Natural Disasters Awareness Raising using Virtual Worlds

	<p>Change the height to 8 or more, if you wish your door to be taller</p>
	<p>Place the Hole shape on the point where you wish the door to be</p>
	<p>Select the 3 shapes and group them together. You will notice that the grouped shape is monochromus</p>
	<p>If you wish to retain the original colors click on the Solid color and select Multicolor</p>
	<p>Here you are! Congratulations on building your first house!</p>



Working with Text and custom shapes

The Text tool is easy to use when you want to create 3d texts



Select the Text tool from the library of shapes and drag it at the Workplane

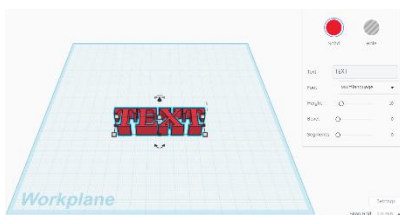

You can change the Text to your own

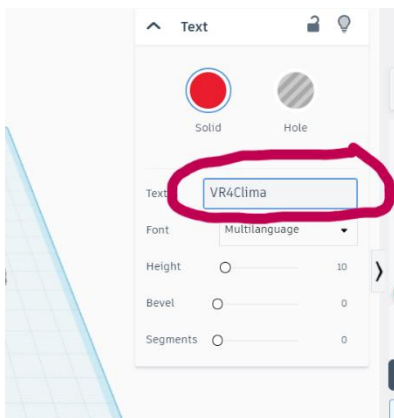

Here's our choice

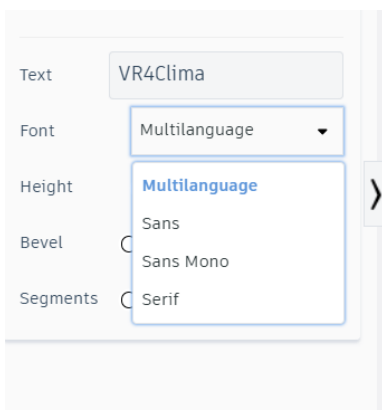

You can choose the fonts you prefer



You can choose individual letters from shapes as well:

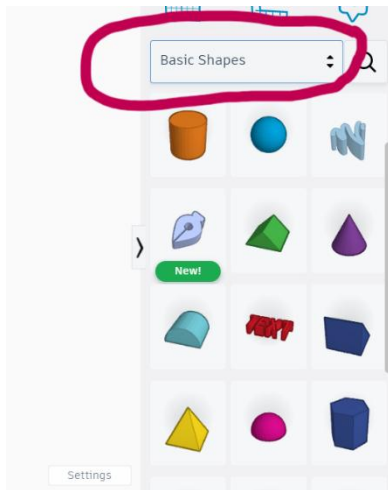

You go to the Shapes Library

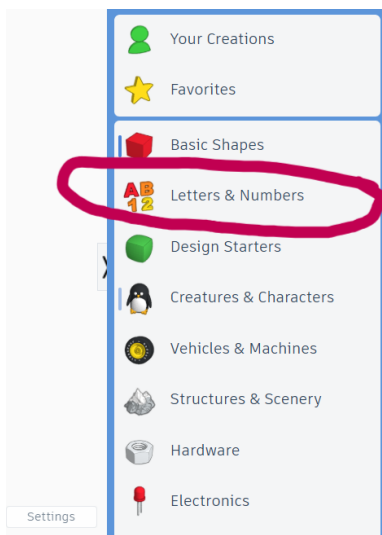

Select "Letters and numbers"

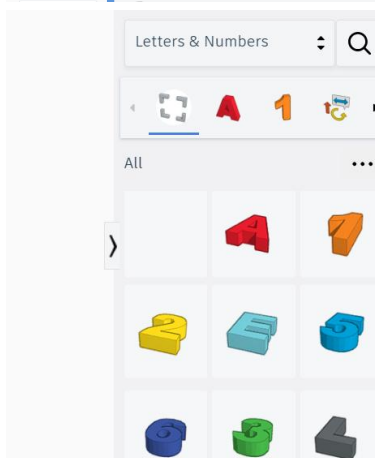

You can choose from a variety of letters and numbers





Let's create a sign

You drag the text sign inside the Workplane and write the text you wish.

	<p>Insert a cylinder in the workplane, next to your text</p>
	<p>Drag the edges of the cylinder so that it is long enough to cover the text</p>
	<p>Click the Top side of your view cube</p>
	<p>Place the cylinder above your text</p>
	<p>Drag the sides of the cylinder so that the text is covered completely</p>

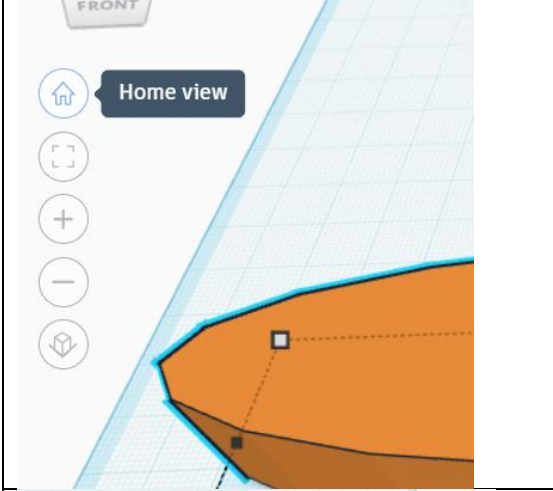
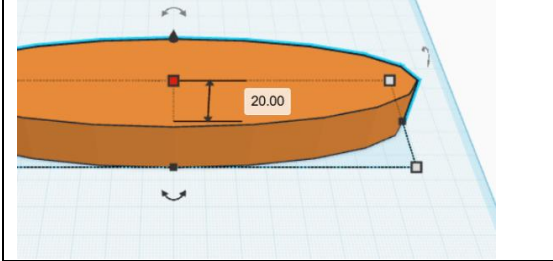
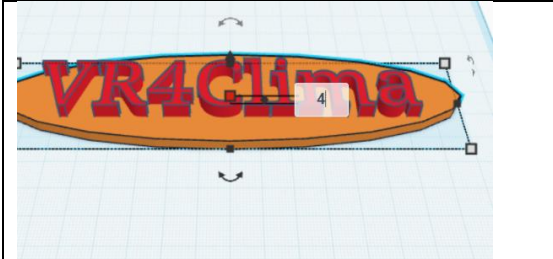

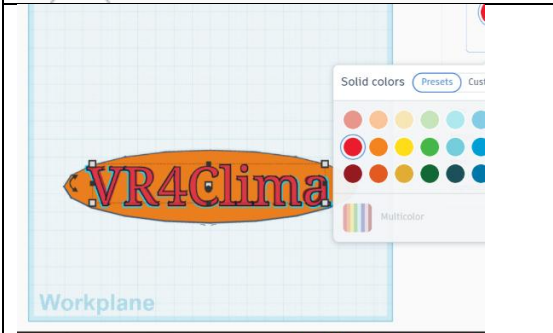
	<p>Click home View in your View menu to get back to your initial view</p>
	<p>Click on the middle white square of the cylinder to select the height</p>
	<p>Select the height of your cylinder, so that the text is visible and clear</p>
	<p>Click on the top side of your view cube</p>
	<p>Select the colors you like for your text and cylinder</p>



	<p>Drag a cylinder next to your sign</p>
	<p>Drag the height of your cylinder as much according to how tall you wish your sign to be</p>
	<p>Select the 2 first shapes either by right clicking your mouse and making a rectangle above them or by left clicking the first and then Ctrl + Click the second. Then Group the shapes together (Click on Group button on the top right Tool bar of your screen)</p>



	<p>You want to rotate the sign so that it is faced forward. You have to select the correct dimension to rotate</p>
	<p>Use the inner side that is scaled to 22,5°</p>
	<p>Rotate it by 90°</p>
	<p>Select the second cylinder and the sign</p>
	<p>Align them in the middle from the front side</p>

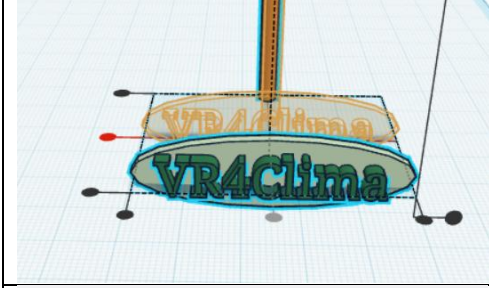
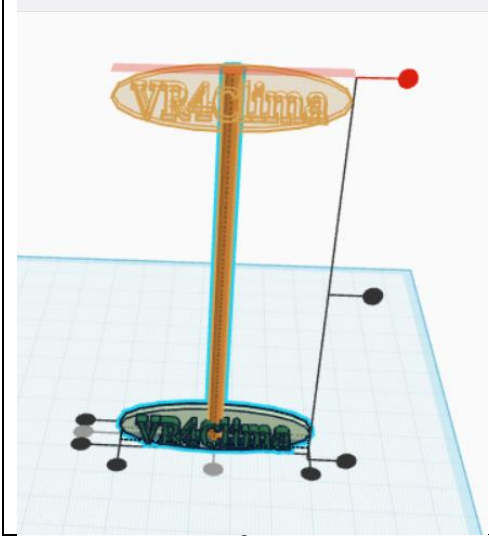
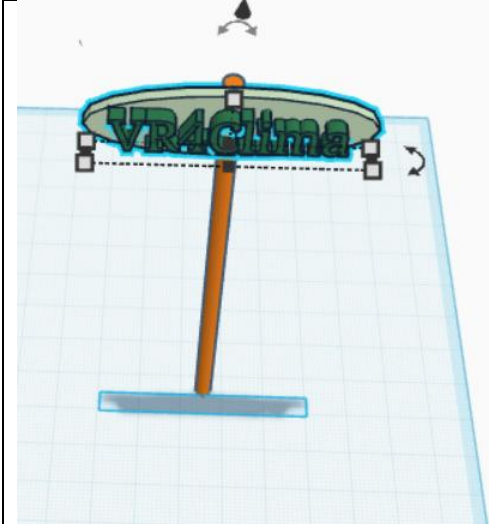

Climate Change and Natural Disasters Awareness Raising using Virtual Worlds

	<p>and from the side</p>
	<p>Last, align on the top of the height</p>
	<p>You have to click 3-4 times the down arrow so that the sign comes in front of the second cylinder.</p> <p>Congratulations! You have created your first sign!</p>



Let's create a greenhouse!

In this example we are going to use the “Duplicate and Repeat” function in a different than usual way

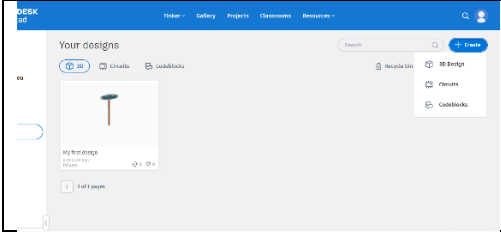
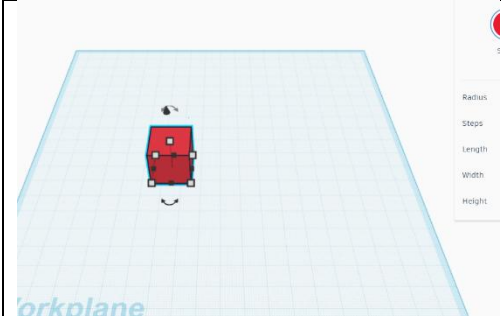
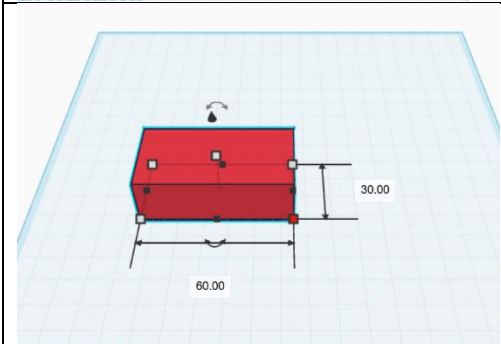
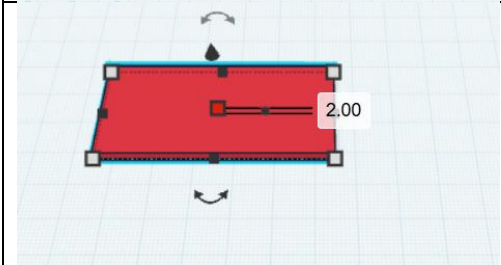
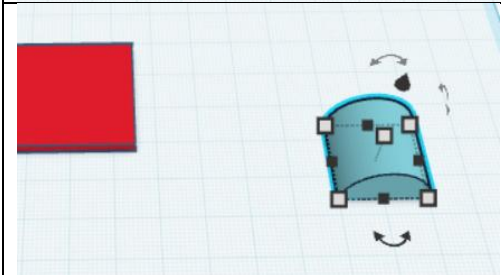
	<p>On the Top Right corner of your screen select Create and then 3d design</p>
	<p>Insert a cube inside your Workplane</p>
	<p>Change the dimensions of Length, Width</p>
	<p>and height</p>
	<p>Insert a round roof from basic shapes</p>



	<p>Change its Width to 30, Length to 1</p>
	<p>and Height to 20</p>
	<p>Click Ctrl+D</p>
	<p>Now you have two similar shapes one on top of the other</p>
	<p>Bring one on front by clicking the Down arrow of your keyboard a couple of times</p>

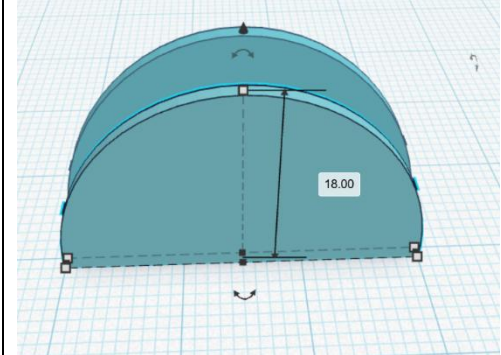
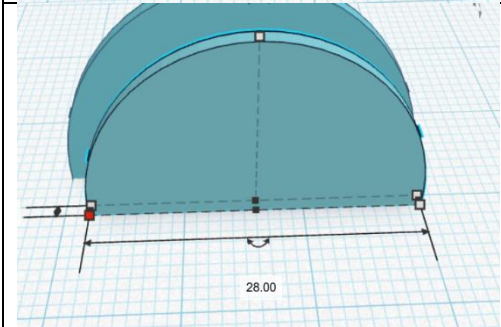
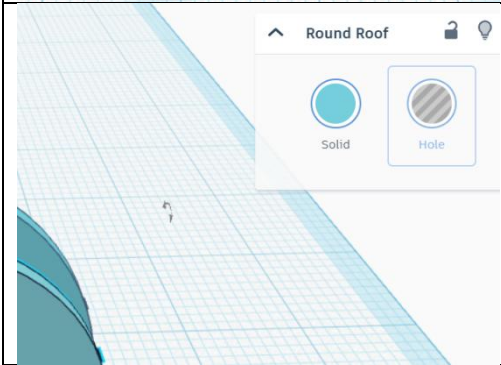
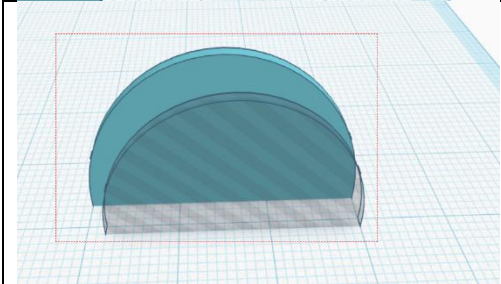
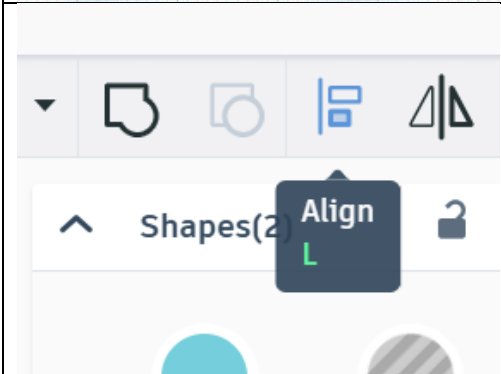

	<p>Change the Height to 18</p>
	<p>and Width to 28</p>
	<p>Make the one with the reduced size a Hole</p>
	<p>And select the 2 shapes by making a rectangle selection by left clicking your mouse button</p>
	<p>Now that both shapes are selected, you will Align them</p>



	<p>On the middle of the Width</p>
	<p>and the middle of the Length</p>
	<p>Group them Together</p>
	<p>And you get a semicircular support beam for your greenhouse</p>
	<p>Rotate it in the correct dimension</p>



Climate Change and Natural Disasters Awareness Raising using Virtual Worlds

	<p>by 90°</p>
	<p>Place it at the left side of your red shape</p>
	<p>Click Duplicate and repeat on the top left corner of your screen</p>
	<p>Using the arrow keys, place the second beam in a distance from the first</p>
	<p>Then click Duplicate and Repeat again</p>



	<p>This command remembers the actions you have done after the first time you clicked on it. The second time you click on it, it duplicates and repeats these actions.</p>
	<p>Bring a new Round Roof in your Workplane</p>
	<p>Change the dimensions as shown</p>
	<p>Change the Height as well</p>
	<p>Click Duplicate and Repeat to get a second Round Roof on top of the first</p>



	<p>Change the Height of the second Round Roof</p>
	<p>Change Width as well, leave Length as it is</p>
	<p>Select both shapes</p>
	<p>Align them</p>



	<p>Select Hole for the second Round Roof</p>
	<p>Select both shapes</p>
	<p>And Group the two shapes together</p>





	<p>Click on the Solid Color and select Transparent on the bottom right of the pop up window</p>
	<p>Bring a Hole Box in your Workplane, change its Height</p>
	<p>its Width and its Length</p>



	<p>Align it with the transparent Round Roof</p>
	<p>Group them together</p>
	<p>Rotate the transparent shape</p>
	<p>By 90° on the Width axe</p>
	<p>Select the first construction of base and supporting beams</p>

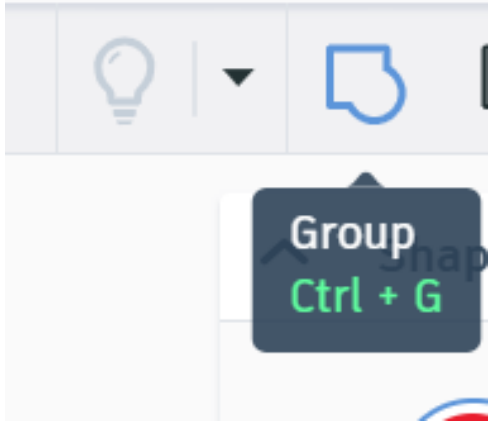
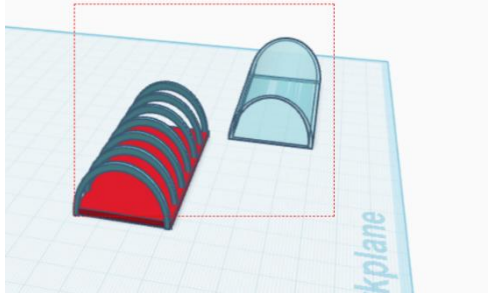
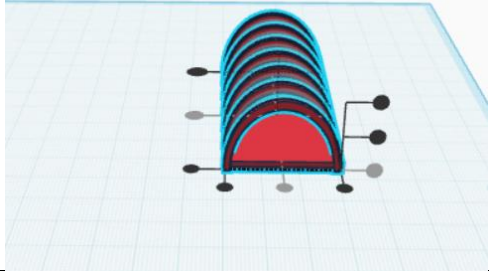

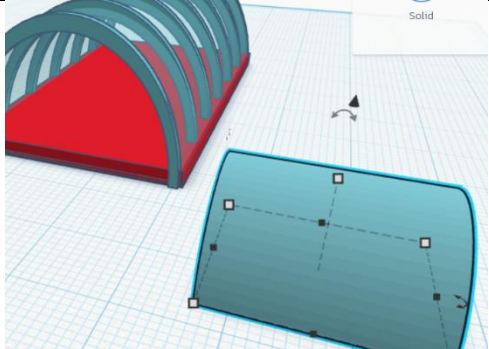
	<p>Group all shapes together</p>
	<p>Then select the two shapes</p>
	<p>Align them</p>
	<p>And you get the greenhouse shape. Now you need to add 2 walls</p>
	<p>Bring a Round Roof in your Workplane</p>



	<p>Rotate it</p>
	<p>Change its dimensions as shown</p>
	<p>Bring a Hole Box in your Workplane</p>



	<p>Change its Width</p>
	<p>and height</p>
	<p>Select the two shapes</p>
	<p>And Align them</p>

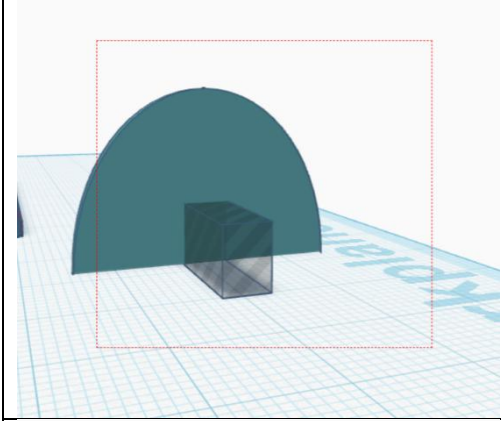
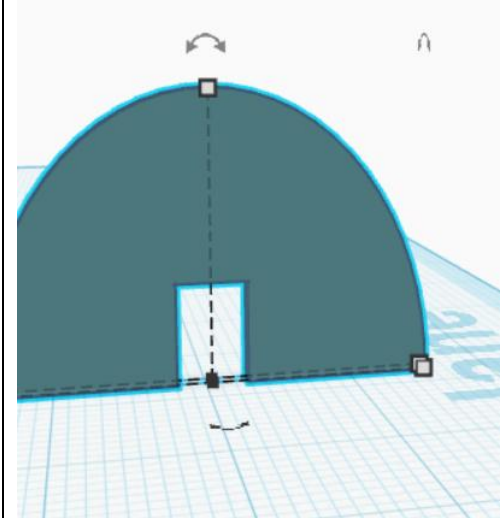
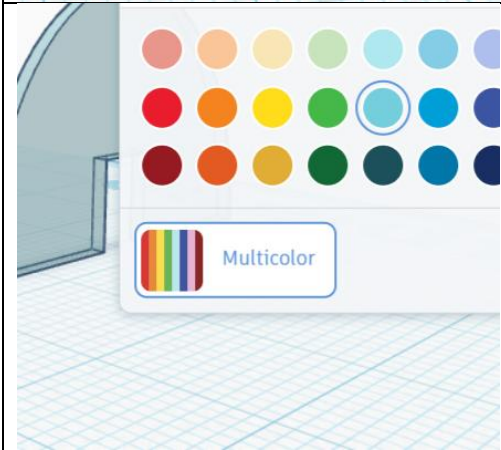
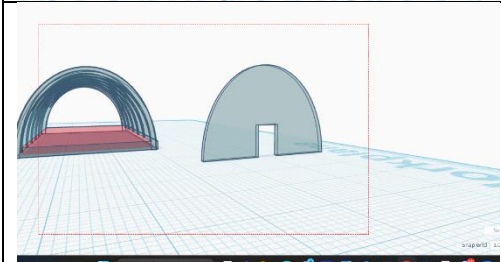

Climate Change and Natural Disasters Awareness Raising using Virtual Worlds

	<p>Select again</p>
	<p>And Group</p>
	<p>Click on Solid and then Transparent</p>
	<p>Select your wall and greenhouse</p>



Climate Change and Natural Disasters Awareness Raising using Virtual Worlds

	<p>Align them</p>
	<p>Then, select the wall again and click Duplicate and Repeat</p>
	<p>Using the arrow keys, bring the second wall on the other side of the greenhouse</p>



Let's create a Windmill

In this example you are going to practice a different way to change the shapes of objects.

- By clicking **Shift** and simultaneously dragging one of the white dots of your shape, it gets bigger or smaller retaining its original shape.

	Drag a cylinder shape on your Workplane
	Change its Width and Length to 30
	Click "Duplicate and repeat"

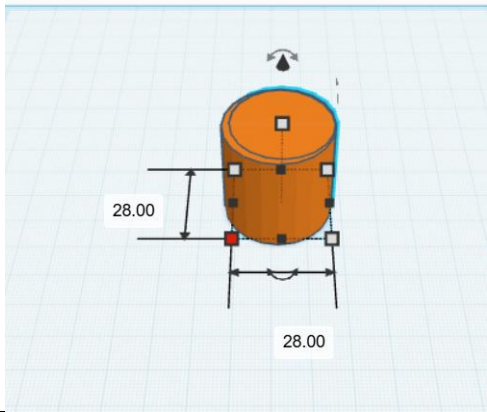
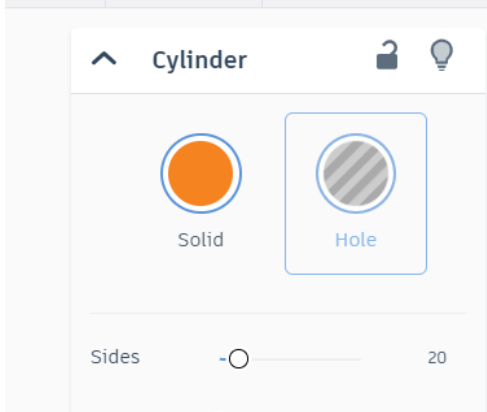
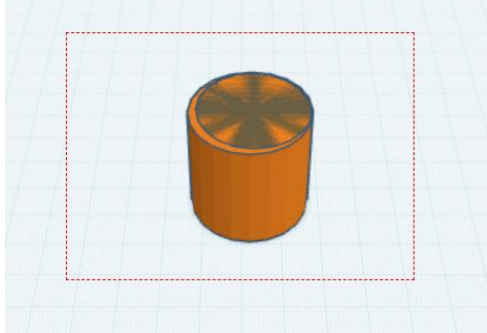
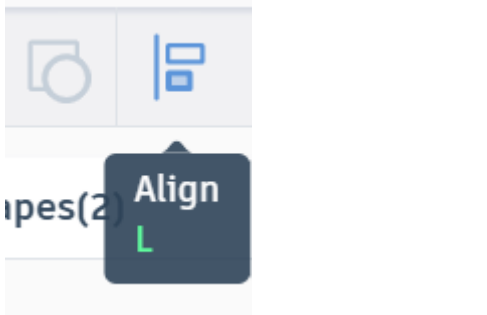

	<p>Change the Width and length of the second cylinder shape to 28</p>
	<p>Click on the "Hole"</p>
	<p>Make a rectangular selection by left clicking your mouse button</p>
	<p>Click on "Align"</p>

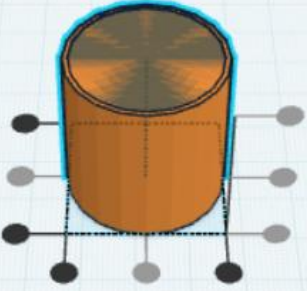
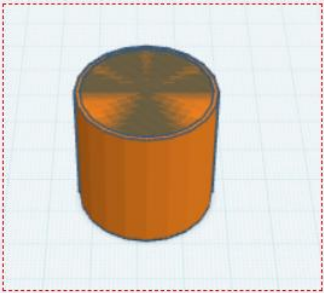
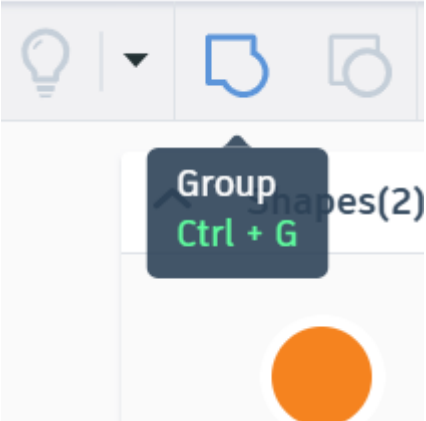
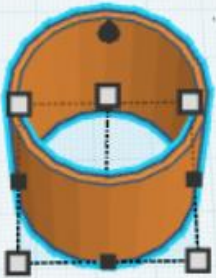

	<p>Align in the middle of the Width and Length</p>
	<p>Select both shapes</p>
	<p>Group them</p>
	



	<p>Drag a Cone shape on your Workplane</p>
	<p>Change the base dimensions</p>
	<p>and its Height</p>
	<p>Change colors</p>
	<p>Lift the roof by 30 from the Workplane, by lifting the black triangle above the Cone</p>



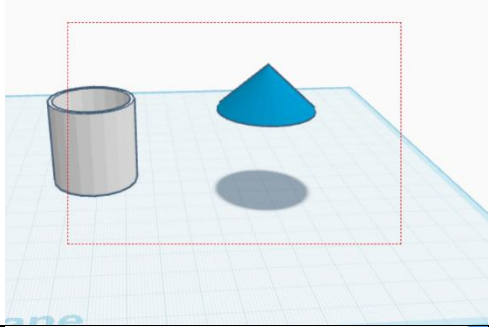
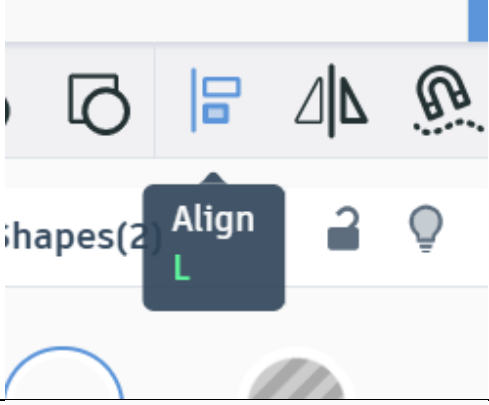
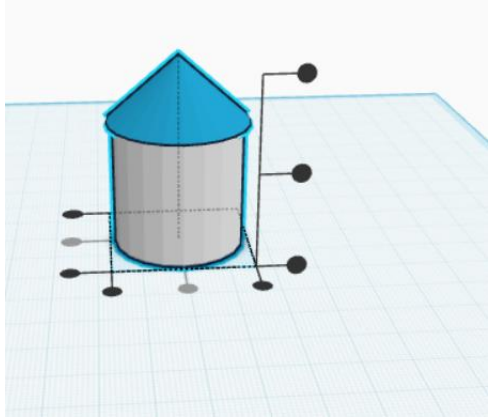
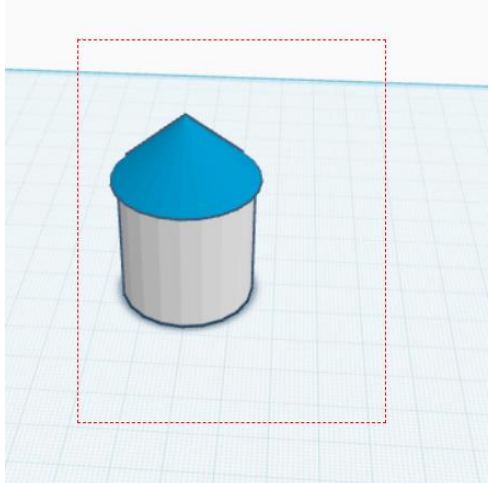

	<p>Select both shapes</p>
	<p>Click on Align</p>
	<p>Align in the middle of Width and Length</p>
	<p>Select both shapes</p>

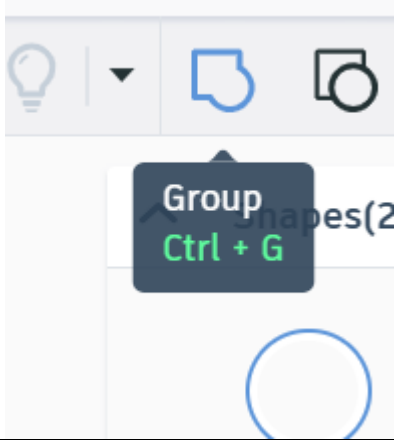
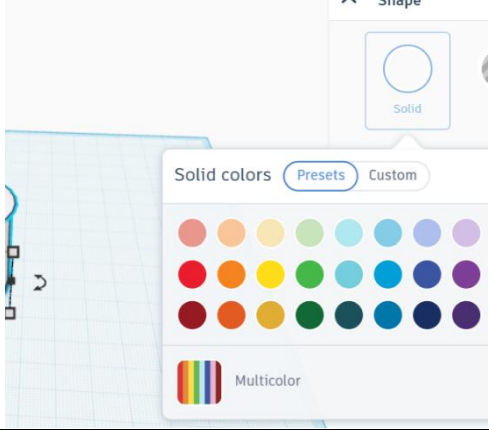
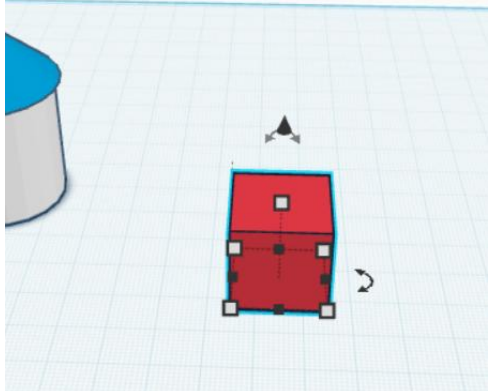

	<p>Group them</p>
	<p>Select "Multicolor"</p>
	<p>Drag a Cube shape on your Workplane</p>

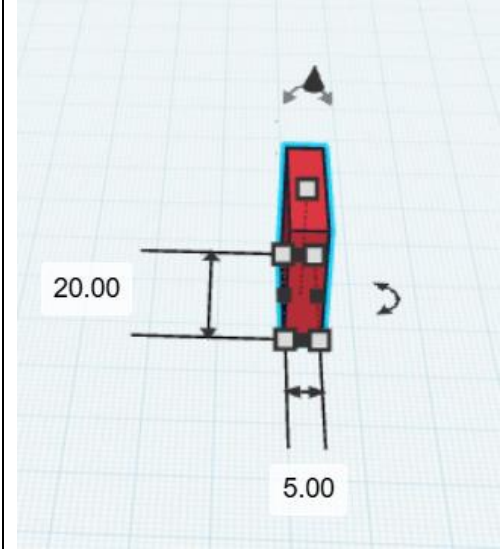
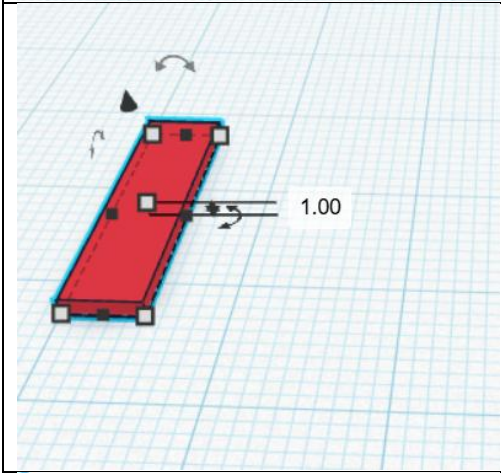

	<p>Change its Width</p>
	<p>and Height</p>
	<p>Click "Duplicate and repeat"</p>



	<p>Move the second shape using the Up Arrow on your Keyboard</p>
	<p>Drag a cylinder shape on your Workplane</p>
	<p>Rotate it</p>



	<p>by 90°</p>
	<p>Change its dimensions</p>



	<p>Select the first box</p>
	<p>Rotate it</p>



	<p>by -22.5°</p>
	<p>Select the second box</p>
	<p>Rotate it</p>



	<p>by 22,5°</p>
	<p>Click on Home View</p>



	<p>Select the cylinder and move it towards the boxes by using the arrow keys of your keyboard</p>
	<p>Click "Duplicate and repeat"</p>
	<p>Click on the Hole</p>



	<p>Move the orange cylinder</p>
	<p>Place the Hole one at its original place</p>

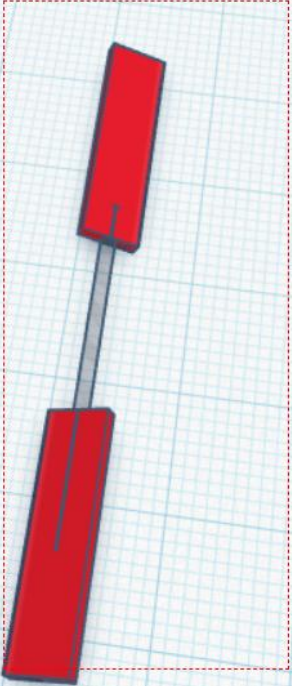
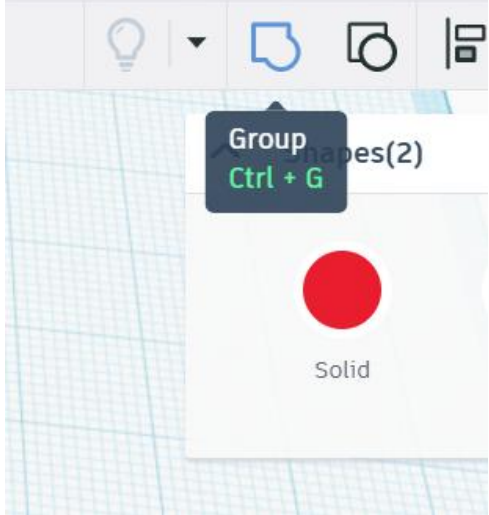

	<p>Select the 3 objects</p>
	<p>and group them</p>



	<p>Then move the orange cylinder back to its original position</p>
	<p>The reason for doing this is so that the red and orange materials do not collide with each other. Select both shapes</p>
	<p>And Group them</p>



	<p>Change the color</p>
	<p>Click "Duplicate and Repeat"</p>
	<p>Rotate the second shape</p>



	<p>by 90°</p>
	<p>Select both shapes</p>
	<p>Group them</p>
	<p>Drag a cylinder shape on the Workplane</p>



	<p>Change its Height</p>
	<p>Change its Width and Length</p>
	<p>Rotate it</p>
	<p>by 90°</p>

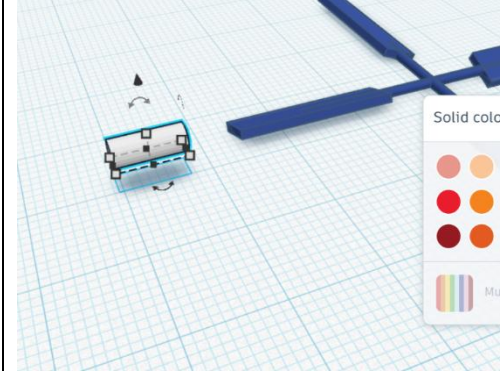
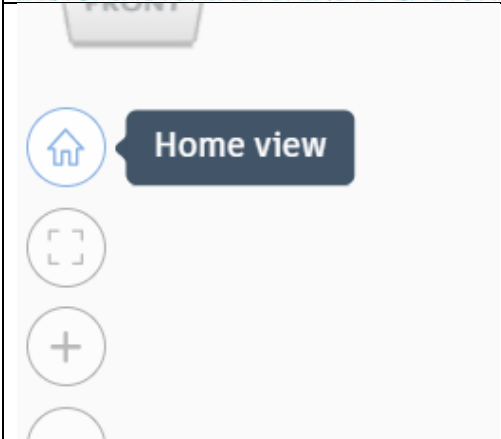
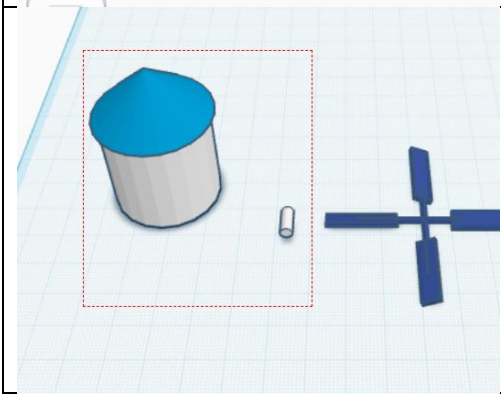
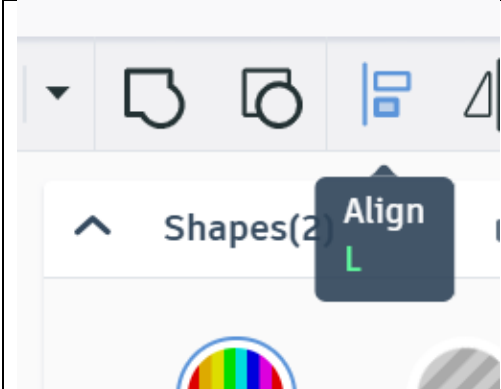

	<p>Change its color to white</p>
	<p>Click on "Home view"</p>
	<p>Select the building and white cylinder</p>
	<p>Click on Align</p>





	<p>Align in the middle of the Width, the front of the Length and the middle of the Height</p>
	<p>Drag the white cylinder a little more outside the building by using the arrow keys</p>
	<p>Lift it up so that it is placed underneath the roof</p>
	<p>Select the shape</p>

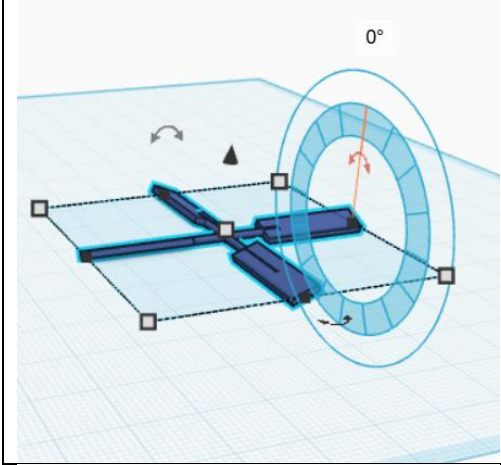
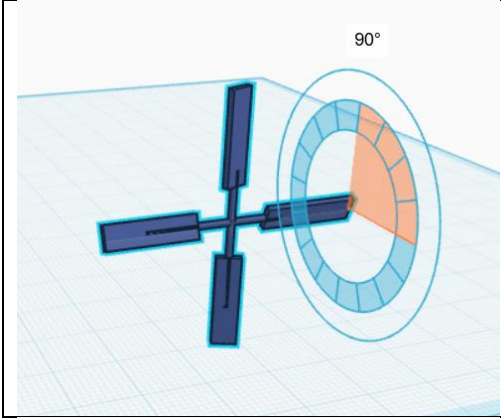
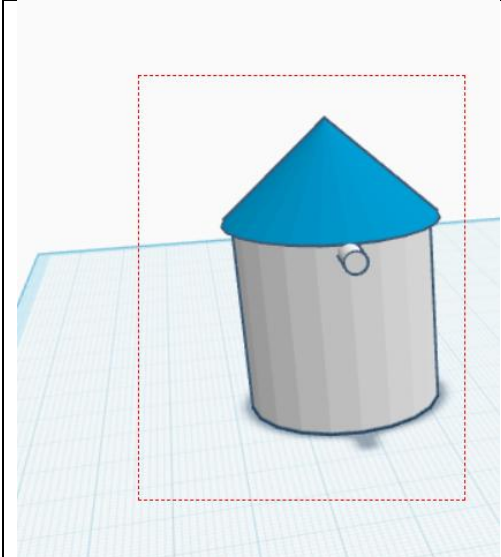

	<p>Rotate it</p>
	<p>by 90°</p>
	<p>Select the building and white cylinder</p>

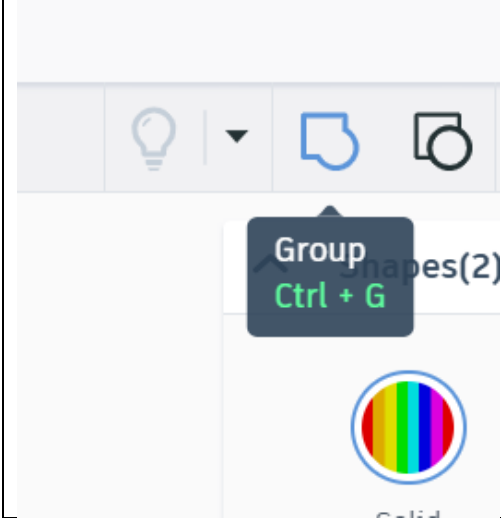
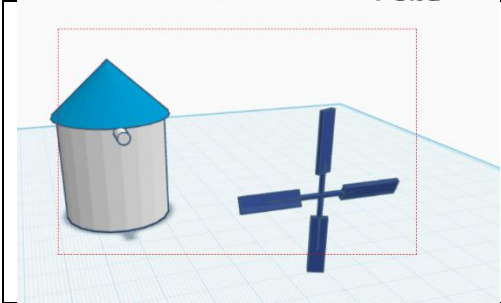
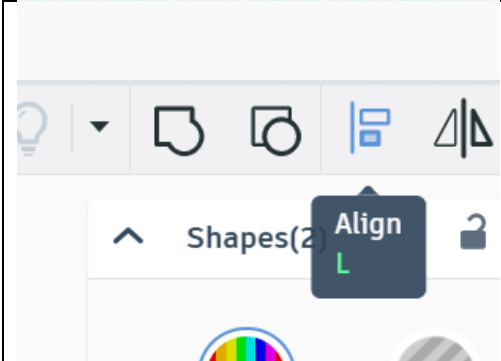
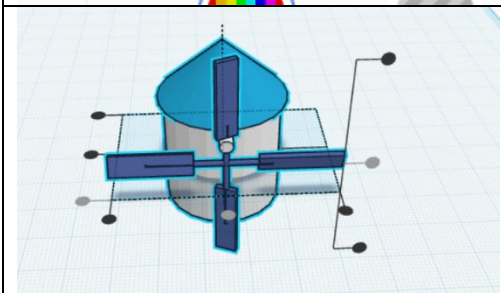

	<p>Group them</p>
	<p>Select the 2 shapes</p>
	<p>Click "Align"</p>
	
	<p>Click the Left side of your View cube</p>



	<p>Select both shapes</p>
	<p>Group them</p>
	<p>Click D to drag the building on the surface of the Workplane</p>

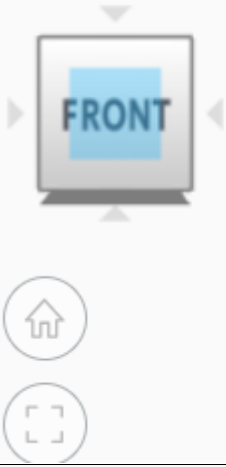
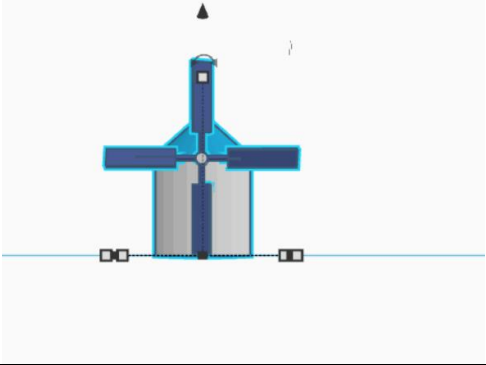
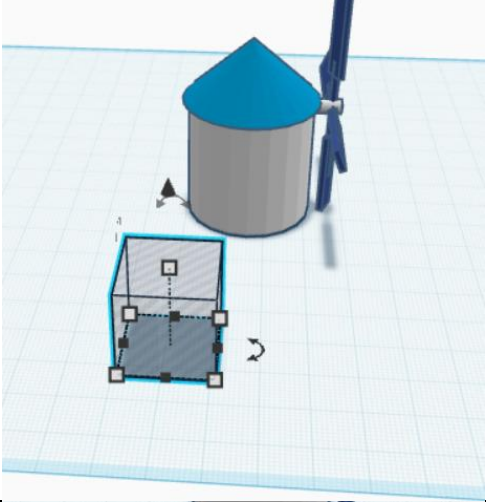
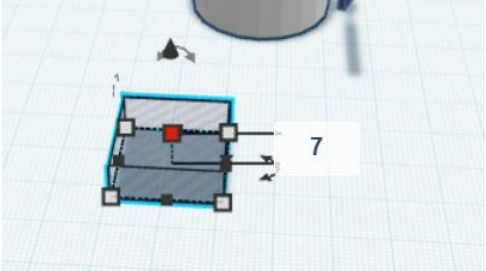

	<p>Click on the Front of your View cube</p>
	
	<p>Bring a Hole box on your Workplane</p>
	<p>Change its height</p>



	<p>And Width</p>
	<p>Select both shapes</p>
	<p>Click "Align"</p>
	<p>Move the Hole box with your arrow keys in order to be placed in the middle of the building</p>



	<p>Select both shapes</p>
	<p>Group them</p>
	<p>Here's your windmill!</p>



Let's create a solar water heater

In this example you will use a new tool, the Mirror Tool. You will also change the grading of the grid to adjust your design

	<p>Drag a cylinder on your Workplane</p>
	<p>Change its Height</p>
	<p>And base dimensions</p>



	<p>Drag a Roof on your Workplane</p>
	<p>Change its dimensions</p>
	<p>Rotate it</p>



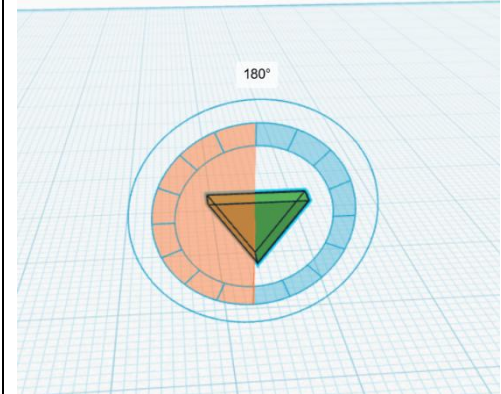
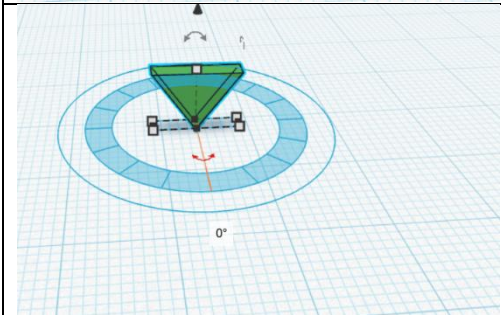
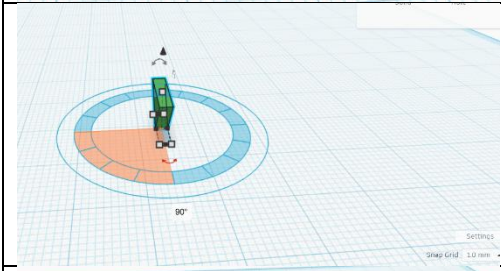
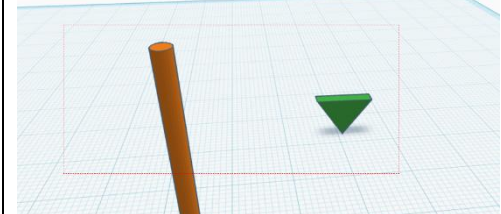
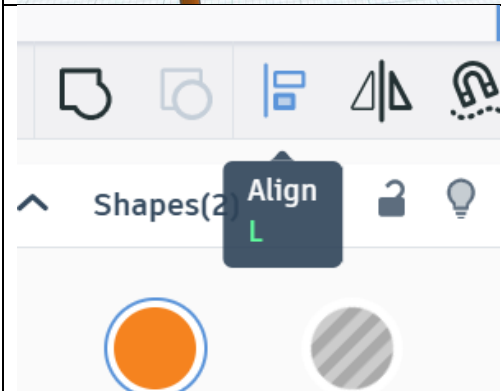

Climate Change and Natural Disasters Awareness Raising using Virtual Worlds

	<p>by 180°</p>
	<p>And then</p>
	<p>by 90°</p>
	<p>Select the Roof and Cylinder</p>
	<p>Click "Align"</p>



	<p>Align it</p>
	<p>Lift the Roof by dragging the black triangle</p>
	<p>like this</p>
	<p>Select both shapes</p>

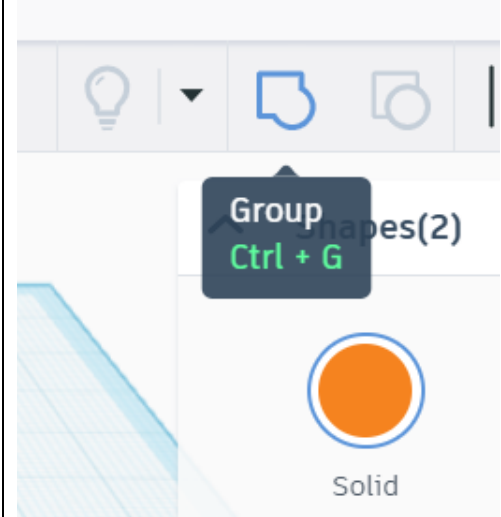
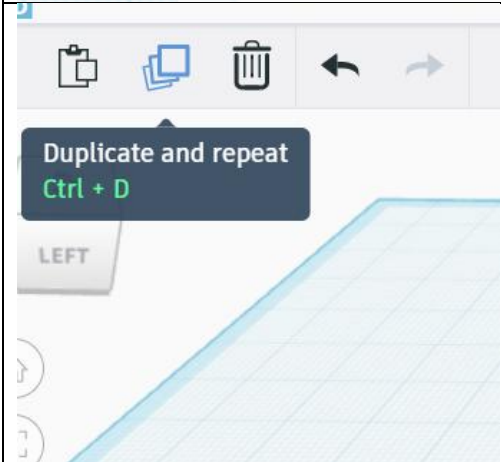

	<p>Group them</p>
	<p>Click "Duplicate and repeat"</p>
	<p>Click on the front side of the View cube</p>



	<p>Use the arrow keys</p>
	<p>To move the second shape next to the first</p>
	<p>Drag a cylinder shape on your Workplane</p>



	<p>Rotate it by 90°</p>
	<p>Change its dimensions</p>
	<p>Rotate it by 22,5°</p>



	<p>Lift it up</p>
	<p>And move it so that it touches both shapes</p>
	<p>The beam is not properly centered and it cannot be by clicking the arrow key</p>

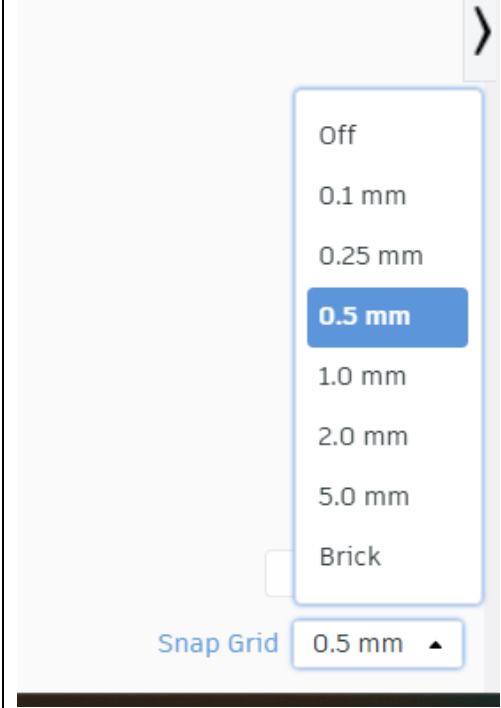
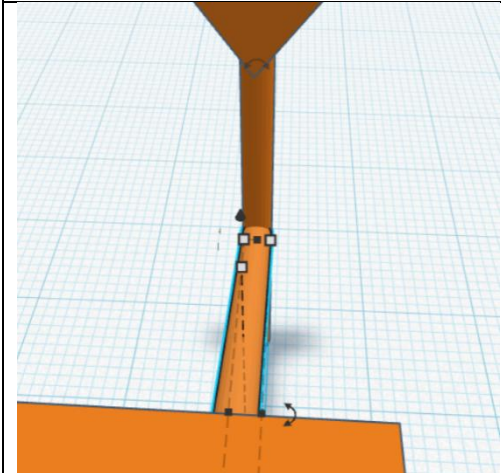
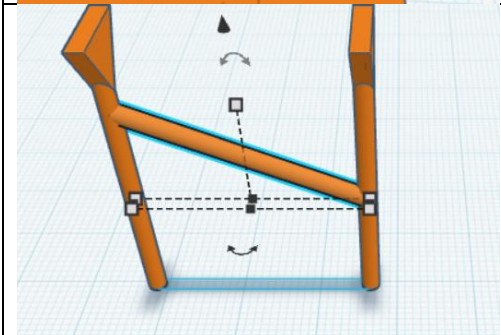

	<p>Go to the Snap Grid and select a 0,5 mm instead of 1mm</p>
	<p>Now, if you move the beam with your arrow key it will be perfectly centered</p>
	<p>Select the beam</p>

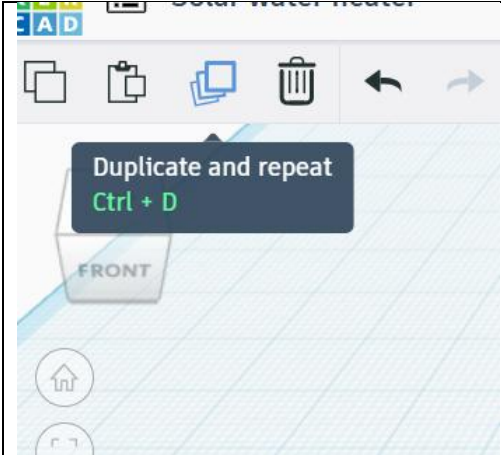
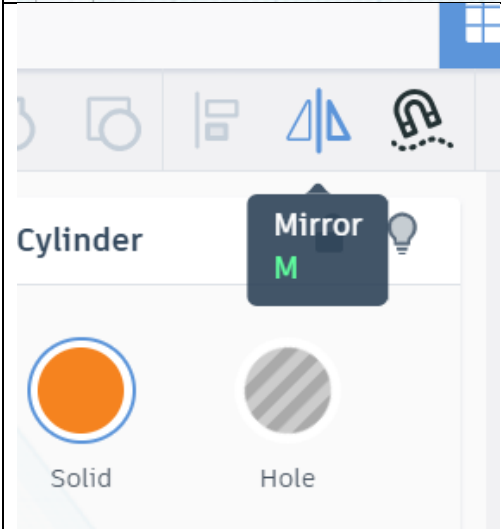
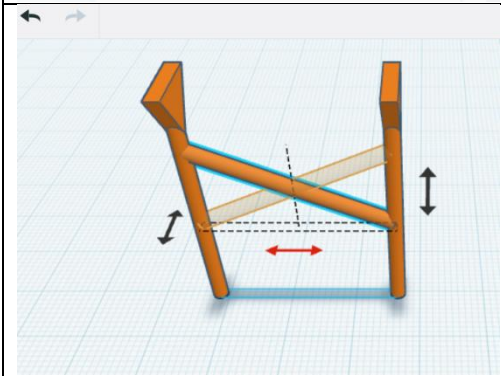
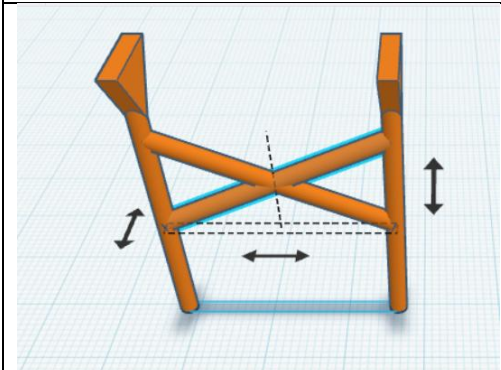

	<p>Click "Duplicate and repeat"</p>
	<p>Select the Mirror Tool</p>
	<p>You have to state in which dimension you want to mirror your object</p>
	

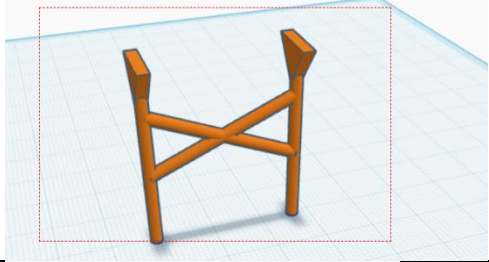
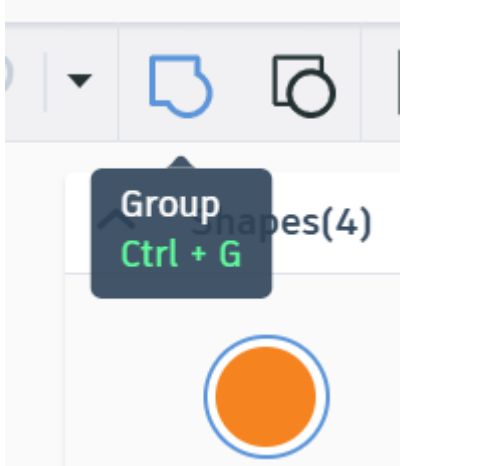
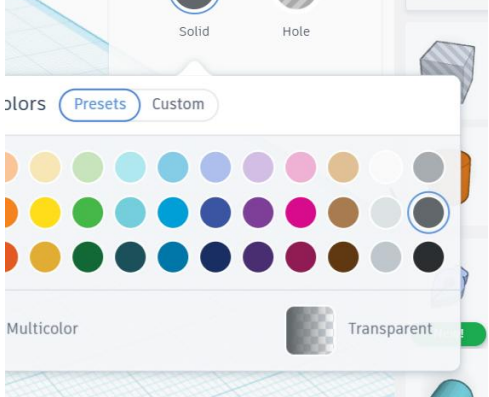
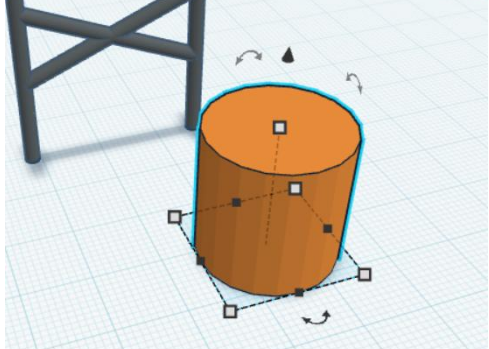

Climate Change and Natural Disasters Awareness Raising using Virtual Worlds

	<p>Select the 3 objects</p>
	<p>And group them</p>
	<p>Change their color</p>
	<p>Drag a cylinder shape on your Workplane</p>

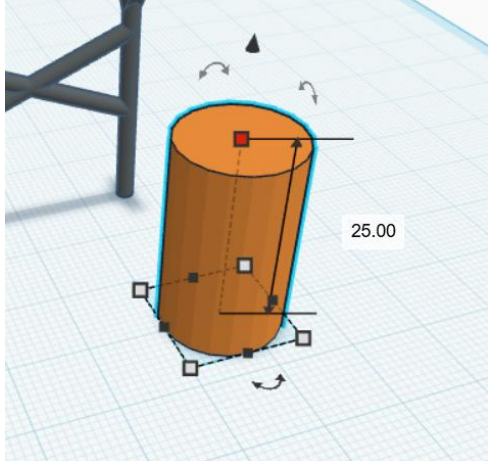
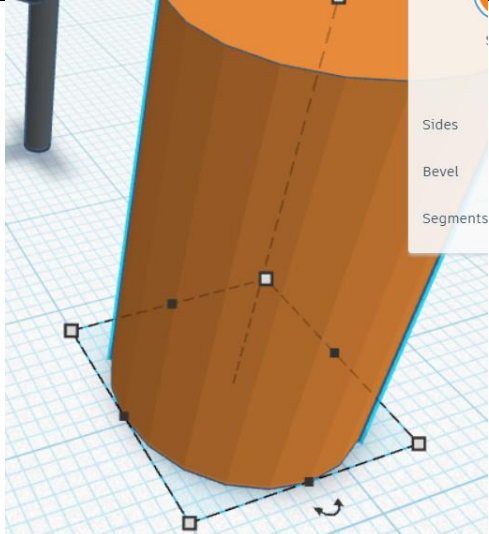
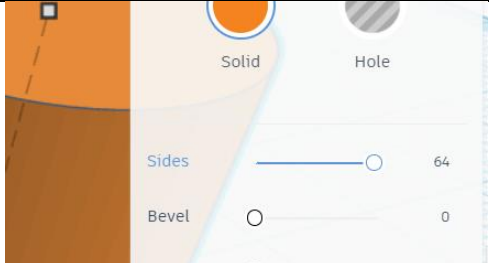
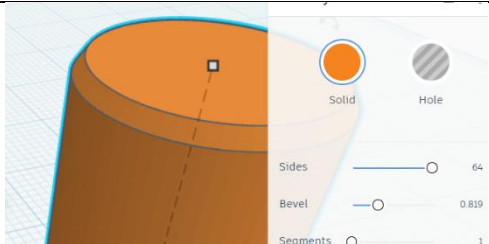

	<p>Make Height 25</p>
	<p>Width and Length are 15. If you notice the surface of your cylinder, the sides are very visible</p>
	<p>If you change the number of Sides to the maximum (64), the surface of the cylinder will look smoother</p>
	<p>If you increase the Bevel, the edges of the cylinder will be smoother</p>



	<p>Rotate the cylinder</p>
	<p>by 90°</p>
	<p>Select both shapes</p>
	<p>Align them</p>

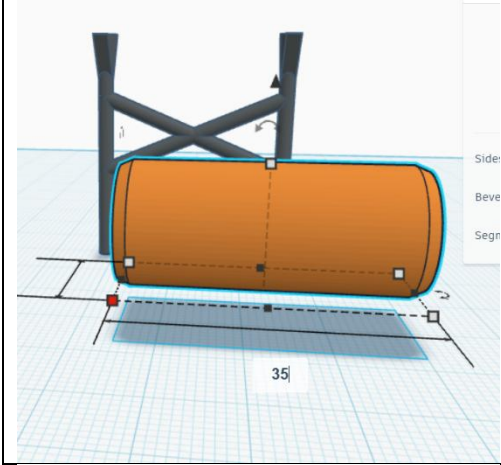
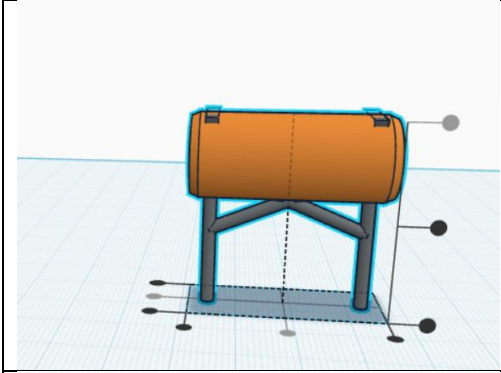
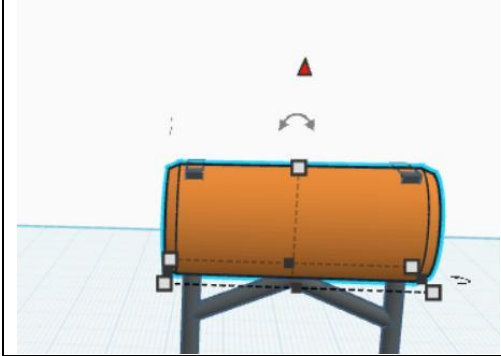
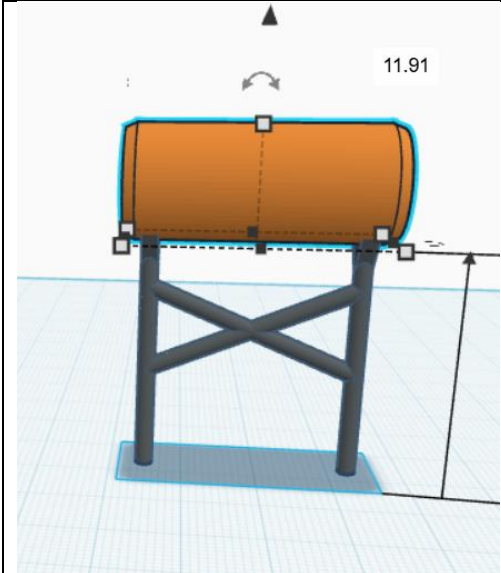

	<p>Change the side of the cylinder to 35 instead of 25</p>
	
	<p>Lift the cylinder up</p>
	

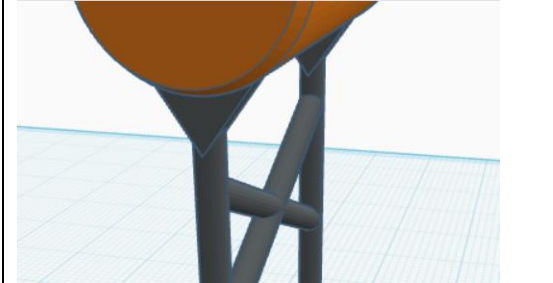
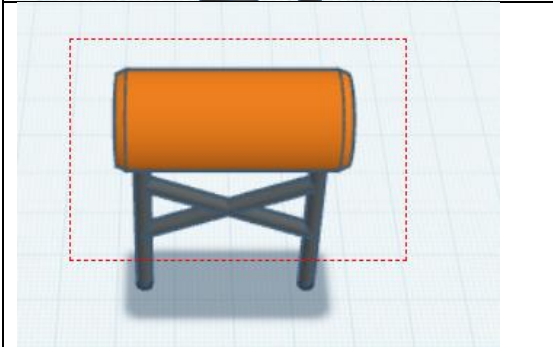
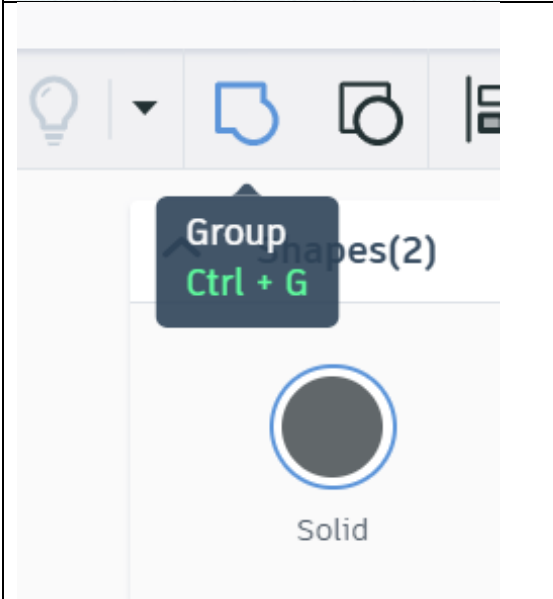

	<p>Click on the Left side of your View cube</p>
	<p>Check that the cylinder sits smoothly on the base. If not, adjust its height</p>
	<p>Select both shapes</p>
	<p>Group them</p>



	<p>Select Multicolor</p>
	<p>Drag a Box shape on your Workplane</p>



	<p>Change its dimensions</p>
	<p>Change its color</p>
	<p>Click "Duplicate and repeat"</p>

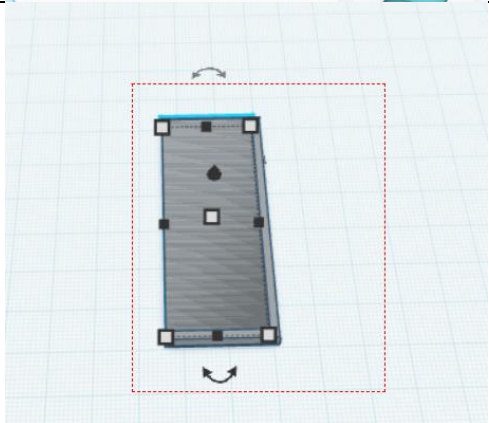

Climate Change and Natural Disasters Awareness Raising using Virtual Worlds

	<p>Change the dimensions of the second shape</p>
	<p>Select Transparent</p>
	<p>Select both shapes</p>

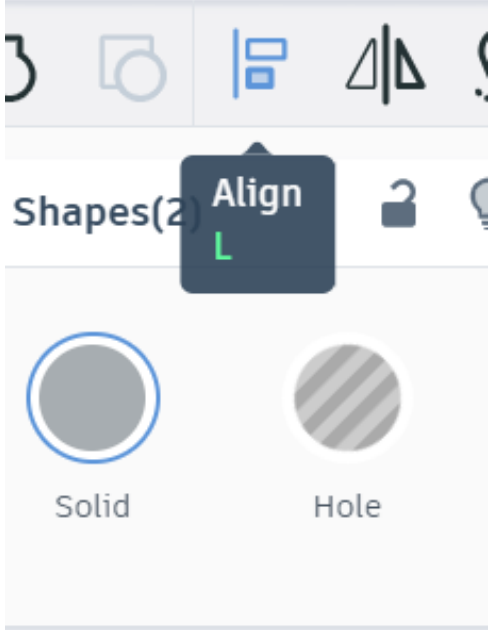
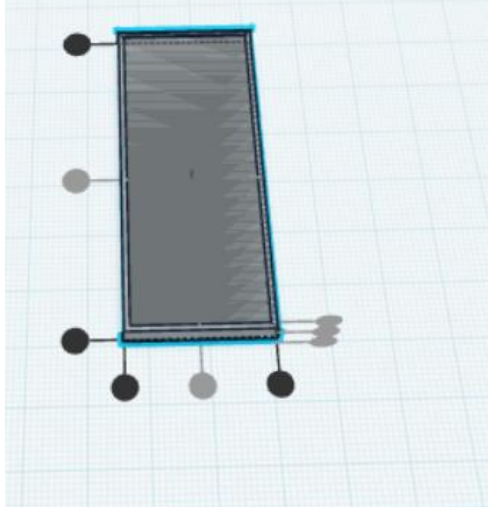
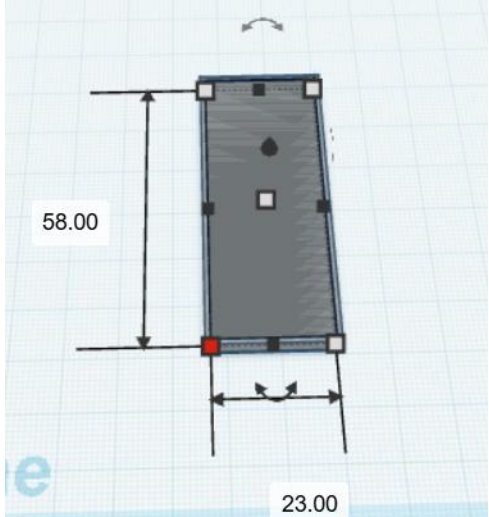

	<p>Align them</p>
	
	<p>Select the transparent shape</p>

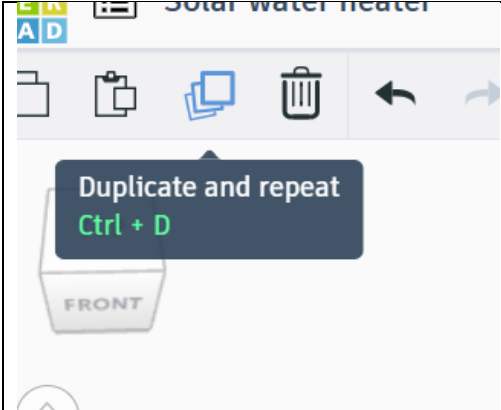
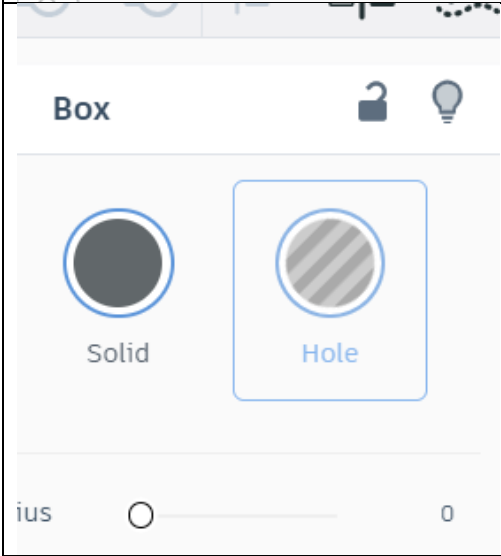
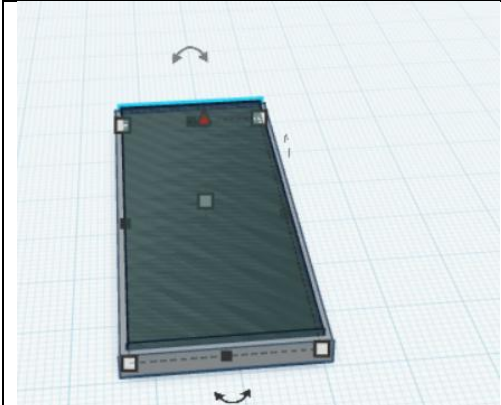

	<p>Click Duplicate and repeat</p>
	<p>Make the duplicated object a Hole</p>
	<p>Select the Hole and the grey object. To do that you click on the Hole shape and then you click Ctrl and the grey shape. You should not select the transparent shape as well because you do not want it to be deleted</p>

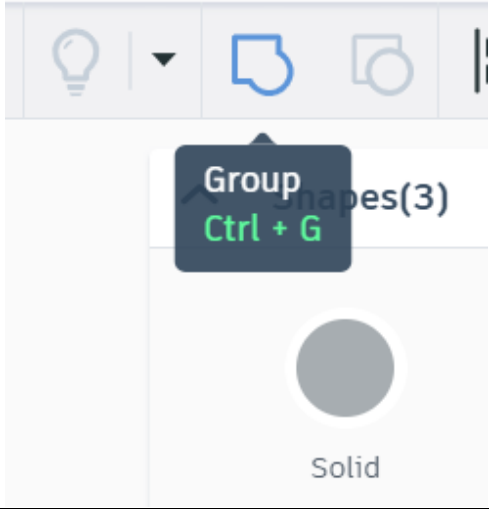
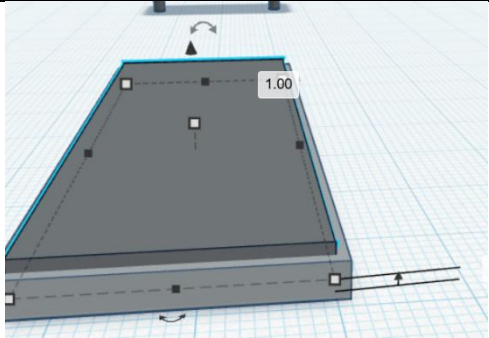
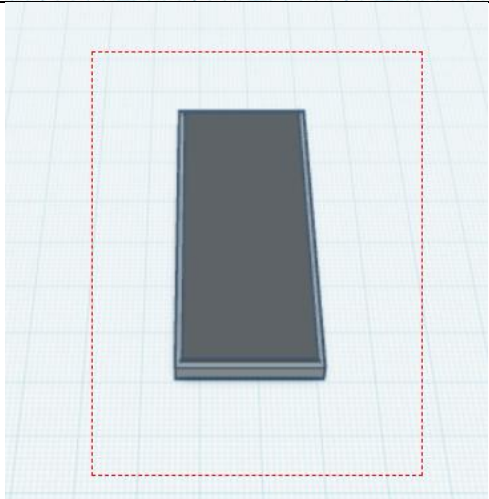

	<p>Group</p>
	
	<p>Select both shapes</p>

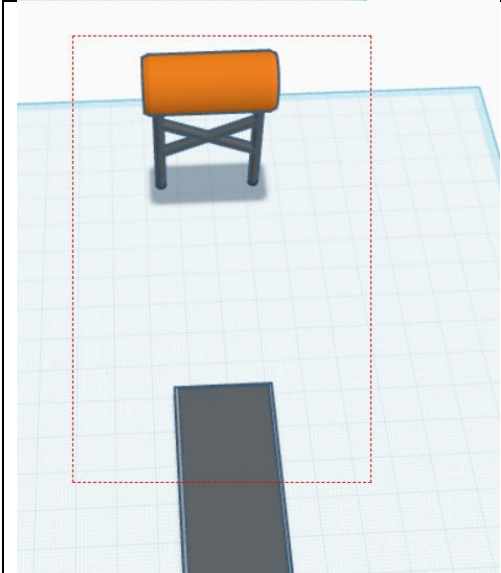

	<p>Group them</p>
	<p>Select Multicolor</p>
	<p>Select both</p>

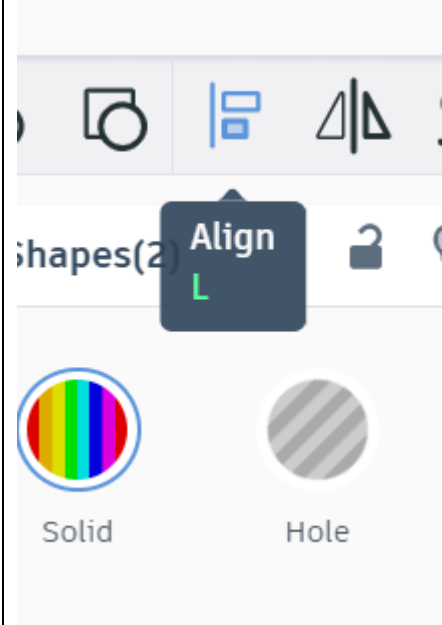
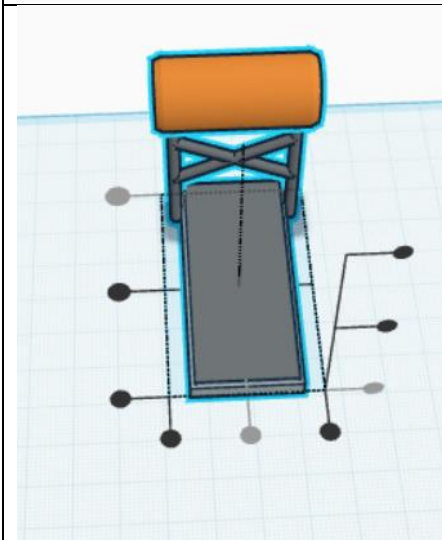
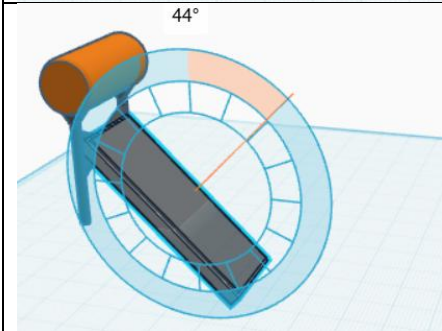
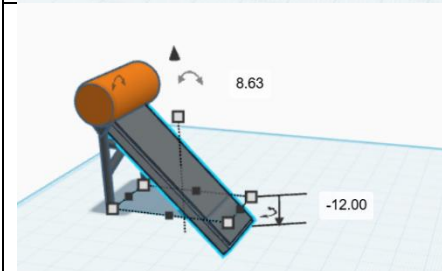

	<p>Align them</p>
	
	<p>Rotate the grey shape</p>
	<p>Lift it up so that it touches the Workplane. You could also click D</p>

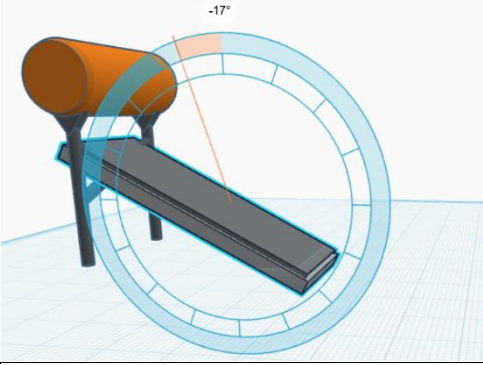
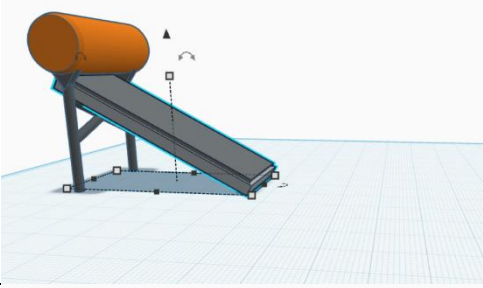
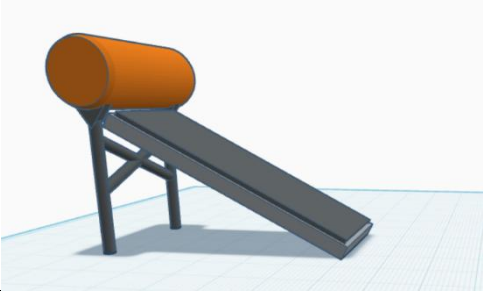
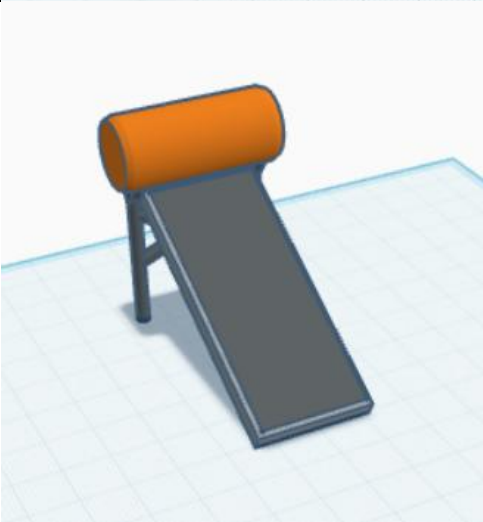

	<p>Rotate again</p>
	
	
	<p>Here's your solar water heater!</p>



Create your class in Tinkercad

Till now, you have created a personal Tinkercad account where you can create your designs.

Now, you want your students to be able to design in Tinkercad.

Students could create their own personal accounts, although it requires parental consent, which makes matters a little complex. Also, teachers would like to have an update on what their students are creating.

For this reason, what you should do is create a class (or more) in Tinkercad. In order to do that, first you have to declare that you are an educator. To do that you have to complete the following steps:

First, you log out of your Tinkercad account.

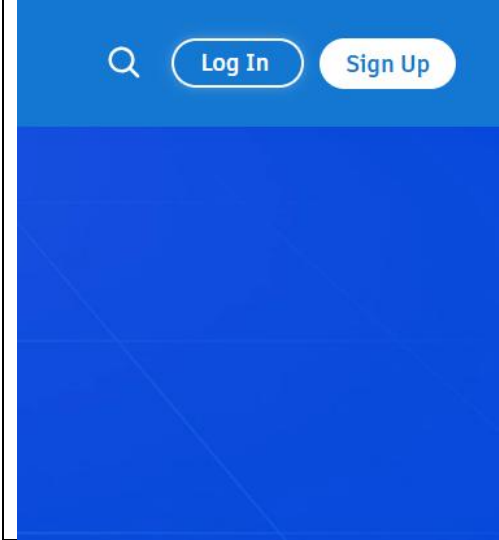
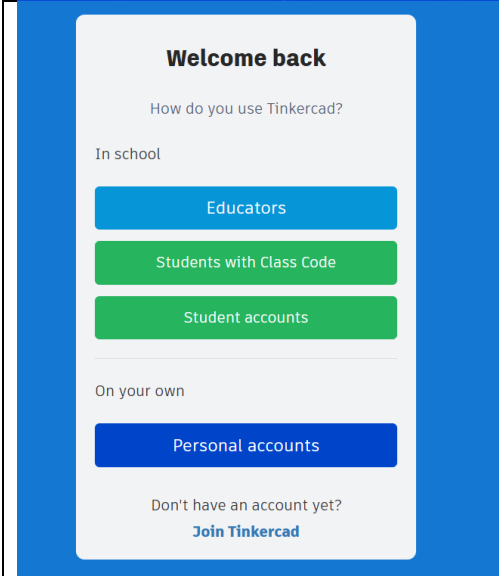
	<p>Then, you click Log In</p>
	<p>This time you click on Educators</p>

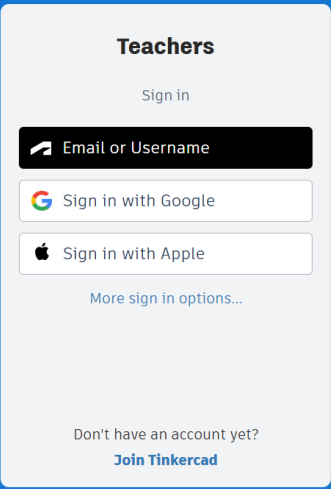
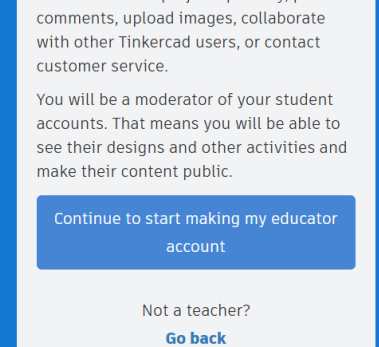
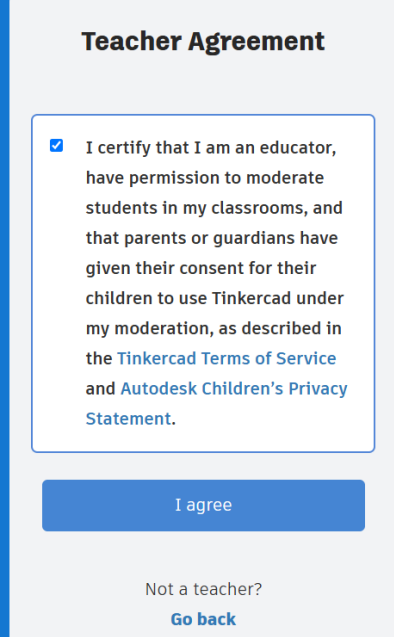

	<p>Sign in with your Google account or with any other way you signed in the first time</p>
	<p>Click continue</p>
	<p>Tick on the box and click "I agree"</p>

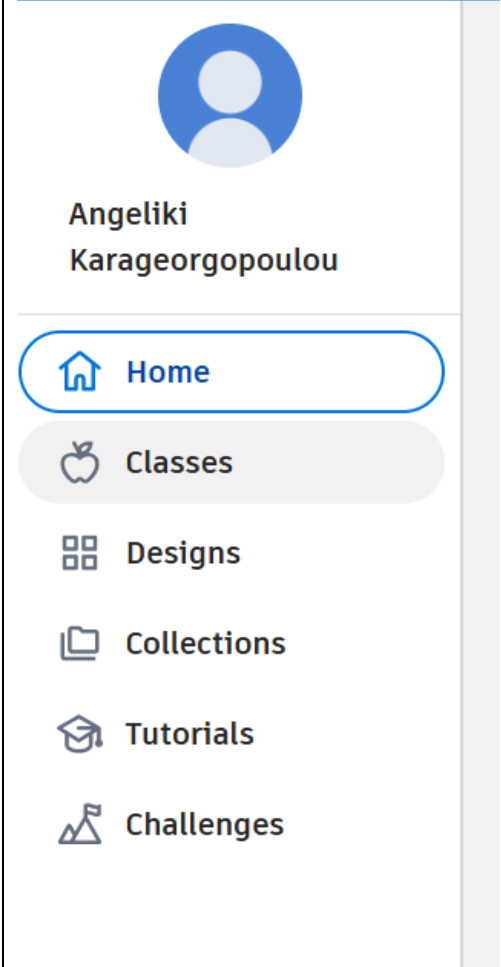
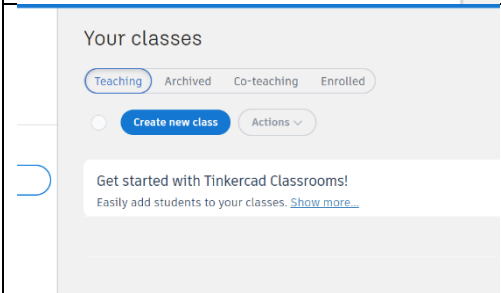
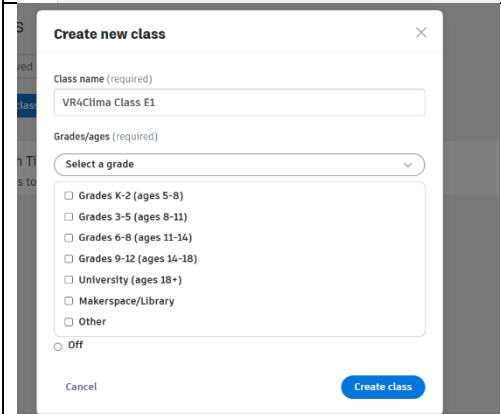

	<p>Click on Classes</p>
	<p>Click on "Create new class"</p>
	<p>Give a name to your class and select the relevant grade</p>

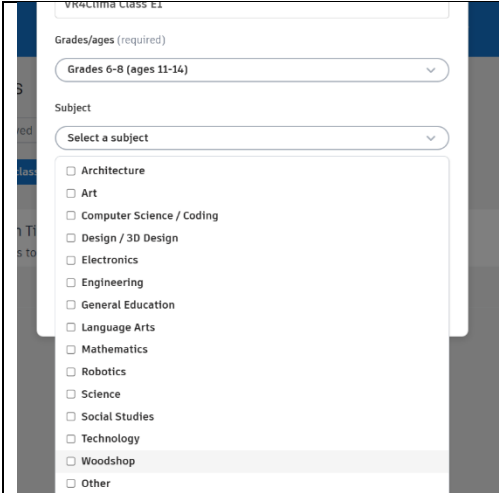
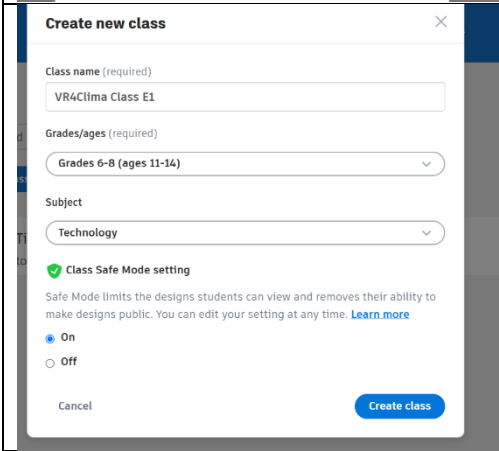
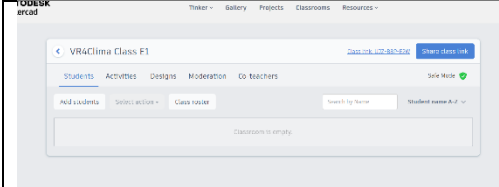
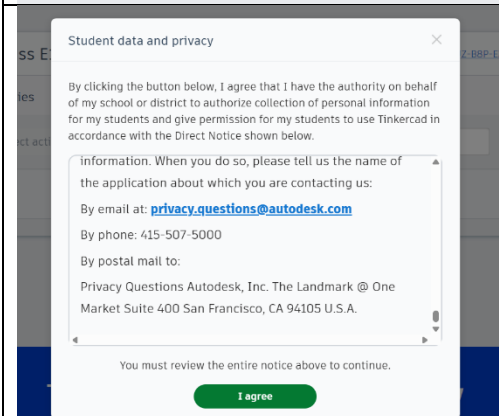

Climate Change and Natural Disasters Awareness Raising using Virtual Worlds

	<p>Select a subject</p>
	<p>Click on "Create class"</p>
	<p>Now it's time to add students in your class. Click on "Add students"</p>
	<p>Click "I Agree" after you have read the whole text</p>



Climate Change and Natural Disasters Awareness Raising using Virtual Worlds

	<p>Add the full name of the first student and a nickname associated with it</p>																		
	<p>Add the rest of the students</p>																		
	<p>Once you have added all your students, click on "Class roster"</p>																		
<table border="1"> <thead> <tr> <th>Name</th> <th>Class code</th> <th>Nickname</th> </tr> </thead> <tbody> <tr> <td>Max Dragovic</td> <td>UJ2B8P2W</td> <td>maxd</td> </tr> <tr> <td>Daren Field</td> <td>UJ2B8P2W</td> <td>darend</td> </tr> <tr> <td>Jenny Kohl</td> <td>UJ2B8P2W</td> <td>jerrykohl</td> </tr> <tr> <td>John Connor</td> <td>UJ2B8P2W</td> <td>johnc</td> </tr> <tr> <td>George Kakarountas</td> <td>UJ2B8P2W</td> <td>georgok</td> </tr> </tbody> </table>	Name	Class code	Nickname	Max Dragovic	UJ2B8P2W	maxd	Daren Field	UJ2B8P2W	darend	Jenny Kohl	UJ2B8P2W	jerrykohl	John Connor	UJ2B8P2W	johnc	George Kakarountas	UJ2B8P2W	georgok	<p>You can print this and give each student their credentials in order to enter the class</p>
Name	Class code	Nickname																	
Max Dragovic	UJ2B8P2W	maxd																	
Daren Field	UJ2B8P2W	darend																	
Jenny Kohl	UJ2B8P2W	jerrykohl																	
John Connor	UJ2B8P2W	johnc																	
George Kakarountas	UJ2B8P2W	georgok																	

Let's see your students' interface now.

	<p>Have your students go to Tinkercad website and click on</p>
--	----------------------------------------------------------------



Climate Change and Natural Disasters Awareness Raising using Virtual Worlds

	<p>The have to type in the class code</p>
	<p>and click "Join with Nickname"</p>
	<p>Then click the green button</p>
	<p>They can create a new design or click on an activity you have added</p>

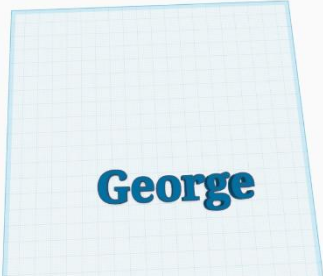

Climate Change and Natural Disasters Awareness Raising using Virtual Worlds

	<p>Let's suppose that this student created his name in 3d</p>
-----------------------------------------------------------------------------------	---------------------------------------------------------------

Now, let's go back to the educator's interface. We will see how the teacher can access the students' designs

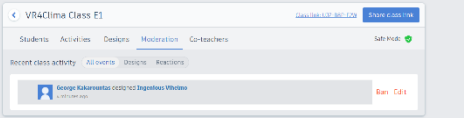
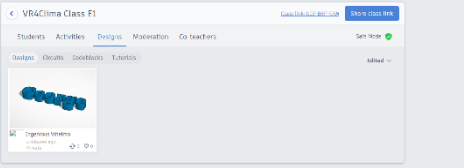
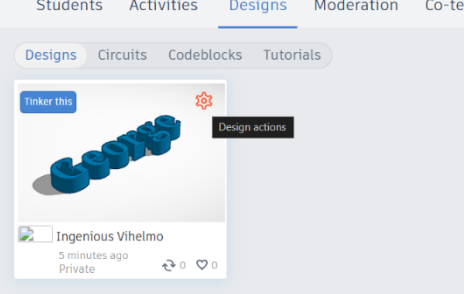
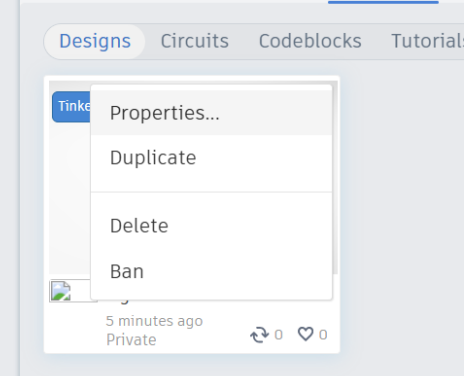
	<p>When you click on the "Moderation" button, you can see your students' activity</p>
	<p>When you click on the "Designs" button, you can access your students' designs</p>
	<p>If you click on the Design actions</p>
	<p>You can Duplicate, Delete or Ban it and also you can add properties</p>

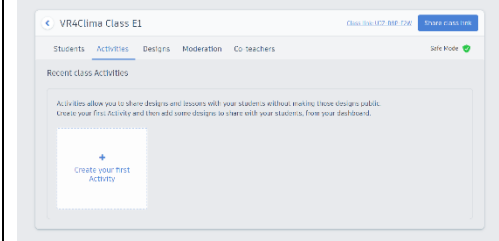
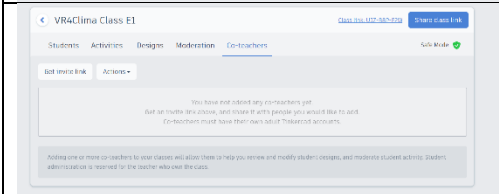

Climate Change and Natural Disasters Awareness Raising using Virtual Worlds

	<p>You can create structured activities for your students</p>
	<p>And invite co-teachers by sending them an invite link</p>